

# **GE 20 PSX**

**1 0 0 7**

**842109003 - GB**

## **USE AND MAINTENANCE MANUAL**

02/02/06 84210M00

Preparato da UPT  
Approvato da DITE

**Main Characteristics of the unit:**

- Three-phase electric power (max) 17.6 kW / 400 V / 50 Hz.
- Perkins Diesel engine 404C / 22G
- Brushless synchronous alternator
- Tank of 60l with autonomy of 14.5 h.
- Dimensions / weight, 1720x980x1110 / 680 Kg.
- Noise level at 7m 67dBA
- Prepared for automatic start unit.
- Prepared for remote start/stop.

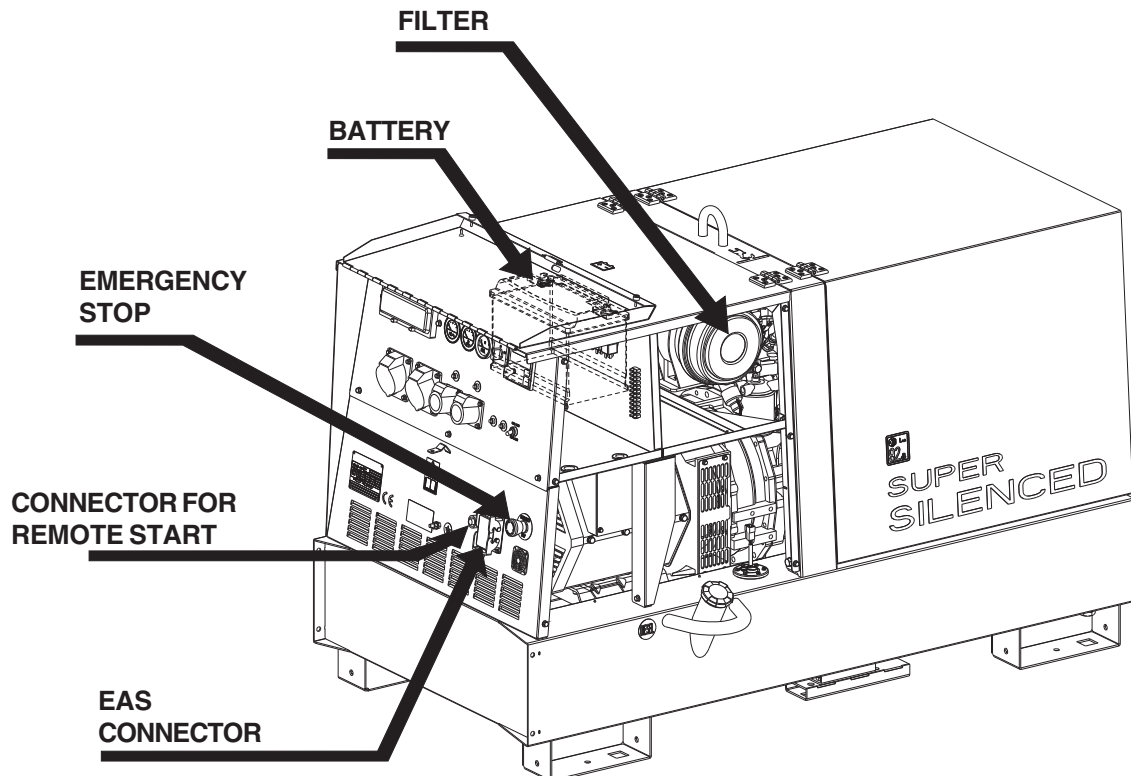

The unit is composed of: a structured base which includes a tank, an engine/alternator unit fixed on the base by 3 elastic dampers, a roll-bar, with hook for an easy and sure lifting, a chest hinged to the roll-bar for a quick access to the engine, a front panel covered with a lid where are mounted the sockets, the protections and the measure instruments. The battery and the engine air filter are protected by a plate hinged to roll-bar and fixed to the structure with 2 rapid block screws with a wrench given as equipment not to be lost.



**UNI EN ISO 9001 : 2000**

ISO 9001:2000 - Cert. 0192

MOSA has certified its quality system according to UNI EN ISO 9001:2000 to ensure a constant, high quality of its products. This certification covers the design, production and servicing of engine driven welders and generating sets.

The certifying institute, ICIM, which is a member of the International Certification Network IQNet, awarded the official approval to MOSA after an examination of its operations at the head office and plant in Cusago (MI), Italy.

This certification is not a point of arrival but a pledge on the part of the entire company to maintain a level of quality of both its products and services which will continue to satisfy the needs of its clients, as well as to improve the transparency and the communications regarding all the company's activities in accordance with the official procedures and in harmony with the MOSA Manual of Quality.

The advantages for MOSA clients are:

- Constant quality of products and services at the high level which the client expects;
- Continuous efforts to improve the products and their performance at competitive conditions;
- Competent support in the solution of problems;
- Information and training in the correct application and use of the products to assure the security of the operator and protect the environment;
- Regular inspections by ICIM to confirm that the requirements of the company's quality system and ISO 9001 are being respected.

All these advantages are guaranteed by the CERTIFICATE OF QUALITY SYSTEM No.0192 issued by ICIM S.p.A. - Milano (Italy) - [www.icim.it](http://www.icim.it)

M 01	QUALITY SYSTEM
M 1.01	COPYRIGHT
M 1.1	NOTES
M 1.4	CE MARK
M 1.5	TECHNICAL DATA
M 1.6	TECHNICAL DATA ENGINE DRIVEN WELDER
M 2-2.1	SYMBOLS AND SAFETY PRECAUTIONS
M 2.5...	INSTALLATION AND ADVICE BEFORE USE
M 2.6	INSTALLATIONS AND ADVICE
M 2.7	INSTALLATION
M 3	PACKING
M 4...	TRANSPORT AND DISPLACEMENTS
M 6...	ASSEMBLY: CT.....
M 20	SETTING-UP THE UNIT (DIESEL ENGINE)
M 21	ENGINE STARTING AND USE (DIESEL ENGINE)
M 22	STOPPING THE ENGINE (DIESEL ENGINE)
M 25	SETTING-UP THE UNIT (GASOLINE ENGINE)
M 26	STARTING THE ENGINE (GASOLINE ENGINE)
M 27	STOPPING THE ENGINE (GASOLINE ENGINE)
M 30	CONTROLS LEGEND
M 31	CONTROLS
M 34	USE AS A WELDER
M 35	USE AS AN ENGINE STARTER
M 36	USE AS A BATTERY CHARGE
M 37...	USE AS A GENERATOR
M 38...	USE OF THE REMOTE CONTROL
M 39...	USE OF THE ENGINE PROTECTION
M 40...	TROUBLE SHOOTING
M 43...	MAINTENANCE
M 45	STORAGE
M 46	CAST OFF
M 53	DIMENSIONS
M 55	RECOMMENDED ELECTRODES
M 60	ELECTRICAL SYSTEM LEGENDE
M 61...	ELECTRICAL SYSTEM
R 1	SPARE PARTS LIST
.....	SPARE PARTS
K...	ACCESSORIES



## ATTENTION

This use and maintenance manual is an important part of the machines in question.

The assistance and maintenance personnel must keep said manual at disposal, as well as that for the engine and alternator (if the machine is synchronous) and all other documentation about the machine.

We advise you to pay attention to the pages concerning the security (see page M1.1).



© All rights are reserved to said Company.

It is a property logo of MOSA division of B.C.S. S.p.A. All other possible logos contained in the documentation are registered by the respective owners.

▮ The reproduction and total or partial use, in any form and/or with any means, of the documentation is allowed to nobody without a written permission by MOSA division of B.C.S. S.p.A.

To this aim is reminded the protection of the author's right and the rights connected to the creation and design for communication, as provided by the laws in force in the matter.

In no case MOSA division of B.C.S. S.p.A. will be held responsible for any damage, direct or indirect, in relation with the use of the given information.

MOSA division of B.C.S. S.p.A. does not take any responsibility about the shown information on firms or individuals, but keeps the right to refuse services or information publication which it judges discutible, unright or illegal.

## INFORMATION

Dear Customer,  
We wish to thank you for having bought from MOSA a high quality set.

Our sections for Technical Service and Spare Parts will work at best to help you if it were necessary.

To this purpose we advise you, for all control and overhaul operations, to turn to the nearest authorized Service Centre, where you will obtain a prompt and specialized intervention.

- ☞ In case you do not profit on these Services and some parts are replaced, please ask and be sure that are used exclusively original MOSA parts; this to guarantee that the performances and the initial safety prescribed by the norms in force are re-established.
- ☞ **The use of non original spare parts will cancel immediately any guarantee and Technical Service obligation from MOSA.**

## NOTES ABOUT THE MANUAL

Before actioning the machine please read this manual attentively. Follow the instructions contained in it, in this way you will avoid inconveniences due to negligence, mistakes or incorrect maintenance. The manual is for qualified personnel, who knows the rules: about safety and health, installation and use of sets movable as well as fixed.

You must remember that, in case you have difficulties for use or installation or others, our Technical Service is always at your disposal for explanations or interventions.

The manual for Use Maintenance and Spare Parts is an integrant part of the product. It must be kept with care during all the life of the product.

In case the machine and/or the set should be yielded to another user, this manual must also given to him.

Do not damage it, do not take parts away, do not tear pages and keep it in places protected from dampness and heat.

You must take into account that some figures contained in it want only to identify the described parts and therefore might not correspond to the machine in your possession.

## INFORMATION OF GENERAL TYPE

In the envelope given together with the machine and/or set you will find: the manual for Use Maintenance and Spare Parts, the manual for use of the engine and the tools (if included in the equipment), the guarantee (in the countries where it is prescribed by law).

Our products have been designed for the use of generation for welding, electric and hydraulic system; ANY OTHER DIFFERENT USE NOT INCLUDED IN THE ONE INDICATED, relieves MOSA from the risks which could happen or, anyway, from that which was agreed when selling the machine; MOSA excludes any responsibility for damages to the machine, to the things or to persons in this case.

Our products are made in conformity with the safety norms in force, for which it is advisable to use all these devices or information so that the use does not bring damage to persons or things.

While working it is advisable to keep to the personal safety norms in force in the countries to which the product is destined (clothing, work tools, etc.).

Do not modify for any motive parts of the machine (fastenings, holes, electric or mechanical devices, others..) if not duly authorized in writing by MOSA: the responsibility coming from any potential intervention will fall on the executioner as in fact he becomes maker of the machine.

- ☞ **Notice:** *this manual does not engage MOSA, who keeps the faculty, apart the essential characteristics of the model here described and illustrated, to bring betterments and modifications to parts and accessories, without putting this manual uptodate immediately.*



Any of our product is labelled with CE marking attesting its conformity to appliable directives and also the fulfillment of safety requirements of the product itself; the list of these directives is part of the declaration of conformity included in any machine standard equipment. Here below the adopted symbol:



CE marking is clearly readable and unerasable and it can be either part of the data-plate (A) or placed as a sticker near the data-plate (B)

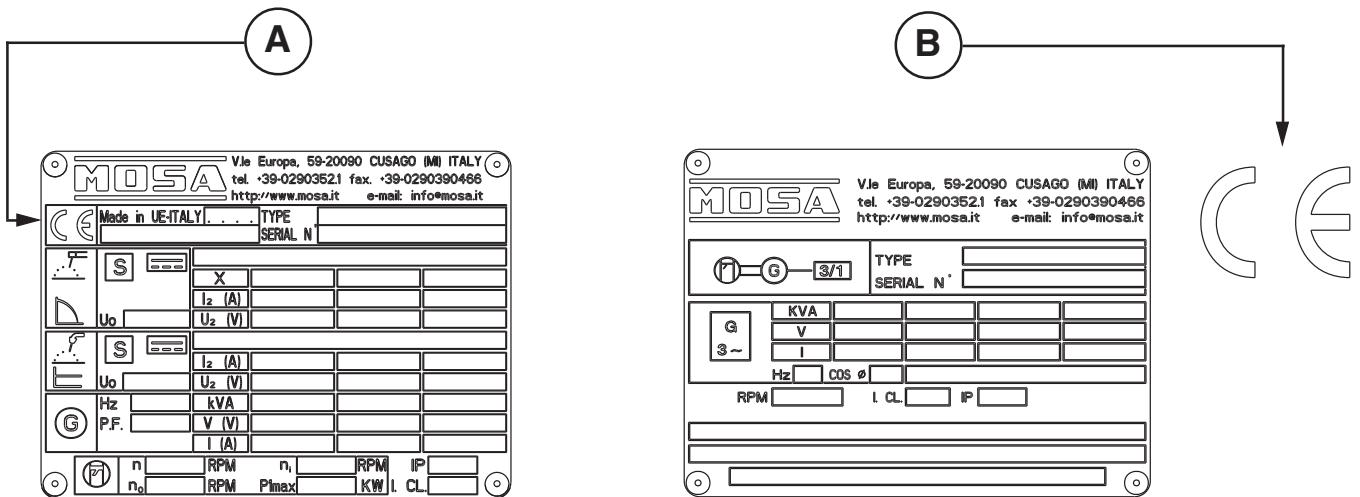

Furthermore, on each model it is shown the noise level value; the symbol used is the following:

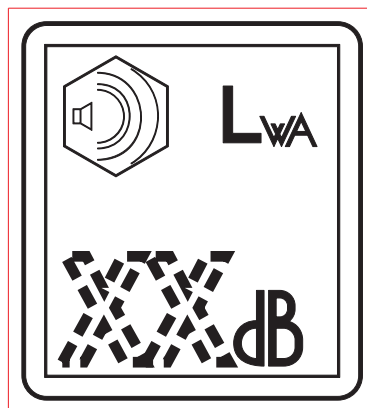

The indication is shown in a clear, readable and indeleble way on a sticker.



The generating set GE 20 is a unit which transforms the mechanical energy, generated by endothermic engine, into electric energy, through an alternator.

Is meant for industrial and professional use, powered by an endothermic engine; it is composed of various main parts such as: engine, alternator, electric and electronic controls, the fairing or a protective structure.

The assembling is made on a steel structure, on which are provided elastic support which must damp the vibrations and also eliminate sounds which would produce noise.

**Technical data****GE 20 PSX****GENERATOR**

<b>Power three-phase (Stand-by)</b>	22 kVA (17.6 kW) / 400 V / 31.8 A
<b>Power three-phase (P.R.P.)</b>	20 kVA (16 kW) / 400 V / 28.9 A
<b>Power single-phase</b>	7.3 kVA / 230 V / 31.8 A
<b>Frequency</b>	50 Hz
<b>Cos φ</b>	0.8

**ALTERNATOR**

	Self-excited, self-regulated, brushless
<b>Type</b>	three-phase, synchronous
<b>Insulation class</b>	H

**ENGINE**

<b>Make</b>	Perkins
<b>Model</b>	404 C-22G
<b>Type</b>	4-Stroke
<b>Displacement</b>	2216 cm <sup>3</sup>
<b>Cylinders</b>	4
<b>Power (max)</b>	20.3 kW (27.6 HP)
<b>Speed</b>	1500 rpm
<b>Fuel consumption</b>	243 g/kWh
<b>Cooling system</b>	Water
<b>Engine oil capacity</b>	8.5 l
<b>Starter</b>	Electric
<b>Fuel</b>	Diesel

**GENERAL SPECIFICATIONS**

<b>Battery</b>	12V - 100Ah
<b>Tank capacity</b>	60 l
<b>Running time (75%)</b>	14.5 h
<b>Protection</b>	IP 23
<b>Dimensions Lxwxh (mm) *</b>	1720x980x1110
<b>Weight *</b>	680 Kg
<b>Noise level</b>	91 LWA (66 dB(A) - 7 m)

\* Dimensions and weight are inclusive of all parts.

**OUTPUT**

Declared powers at the following ambient conditions: temperature 20°C, relative humidity 30% altitude 100 m above sea level.

In an approximative way one reduces: of 1% every 100 m altitude and of 2.5% for every 5°C above 25°C.

For possible modifications or changes to be brought on the engines, with climate conditions different from those above mentioned, please call our Assistance Authorized Centers.

**ACOUSTIC POWER LEVEL**

The machine respects the noise limits, expressed in sound power, given in the a.m. directives.

These limits can be used to judge the sound level produced on site.

For example: the sound power level of 100 LWA.

The sound pressure (noise produced) at 7 meters distance is about 75dBA (the limit value less 25).

To calculate the sound level at other distances use this formula:

$$dBA_x = dBA_y + 10 \log \frac{ry^2}{rx^2} \quad \text{At 4 meters the noise level becomes: } 75 \text{ dBA} + 10 \log \frac{7^2}{4^2} = 80 \text{ dBA}$$



**SYMBOLS IN THIS MANUAL**

- The symbols used in this manual are designed to call your attention to important aspects of the operation of the machine as well as potential hazards and dangers for persons and things.

**IMPORTANT ADVICE**

- Advice to the User about the safety:

 N.B.: The information contained in the manual can be changed without notice. Potential damages caused in relation to the use of these instructions will not be considered because these are only indicative. Remember that the non observance of the indications reported by us might cause damage to persons or things. It is understood, that local dispositions and/or laws must be respected.

**WARNING**



**Situations of danger - no harm to persons or things**

***Do not use without protective devices provided***

Removing or disabling protective devices on the machine is prohibited.

***Do not use the machine if it is not in good technical condition***

The machine must be in good working order before being used. Defects, especially those which regard the safety of the machine, must be repaired before using the machine.

**SAFETY PRECAUTIONS**



**DANGEROUS**

This heading warns of an immediate danger for persons as well for things. Not following the advice can result in serious injury or death.



**WARNING**

This heading warns of situations which could result in injury for persons or damage to things.



**CAUTION**

To this advice can appear a danger for persons as well as for things, for which can appear situations bringing material damage to things.



**IMPORTANT**



**NOTE**



**ATTENTION**

These headings refer to information which will assist you in the correct use of the machine and/or accessories.

**SYMBOLS** (for all MOSA models)



**STOP** - Read absolutely and be duly attentive



Read and pay due attention



**GENERAL ADVICE** - If the advice is not respected damage can happen to persons or things.



**HIGH VOLTAGE** - Attention High Voltage. There can be parts in voltage, dangerous to touch. The non observance of the advice implies life danger.



**FIRE** - Danger of flame or fire. If the advice is not respected fires can happen.



**HEAT** - Hot surfaces. If the advice is not respected burns or damage to things can be caused.



**EXPLOSION** - Explosive material or danger of explosion. in general. If the advice is not respected there can be explosions.



**WATER** - Danger of shortcircuit. If the advice is not respected fires or damage to persons can be caused.



**SMOKING** - The cigarette can cause fire or explosion. If the advice is not respected fires or explosions can be caused.



**ACIDS** - Danger of corrosion. If the advice is not respected the acids can cause corrosions with damage to persons or things.



**WRENCH** - Use of the tools. If the advice is not respected damage can be caused to things and even to persons.



**PRESSION** - Danger of burns caused by the expulsion of hot liquids under pressure.



**ACCES FORBIDDEN** to non authorizad people.

**PROHIBITIONS** No harm for persons

**Use only with safety clothing -**



It is compulsory to use the personal protection means given in equipment.

**Use only with safety clothing -**



It is compulsory to use the personal protection means given in equipment.

**Use only with safety protections -**



It is a must to use protection means suitable for the different welding works.

**Use with only safety material -**



It is prohibited to use water to quench fires on the electric machines.

**Use only with non inserted voltage -**



It is prohibited to make interventions before having disinserted the voltage.

**No smoking -**



It is prohibited to smoke while filling the tank with fuel.

**No welding -**



It is forbidden to weld in rooms containing explosive gases.

**ADVICE** No harm for persons and things

**Use only with safety tools, adapted to the specific use -**

It is advisable to use tools adapted to the various maintenance works.

**Use only with safety protections, specifically suitable**



It is advisable to use protections suitable for the different welding works.

**Use only with safety protections -**



It is advisable to use protections suitable for the different daily checking works.

**Use only with safety protections -**



It is advisable to use all protections while shifting the machine.

**Use only with safety protections -**



It is advisable to use protections suitable for the different daily checking works.and/or of maintenance.



The installation and the general advice concerning the operations, are finalized to the correct use of the machine, in the place where it is used as generator group and/or welder.

<b>ENGINE</b>	Stop engine when fueling	<b>CHECKING BOARD</b>	Do not touch electric devices if you are barefoot or with wet clothes.
	Do not smoke, avoid flames, sparks or electric tools when fueling.		Always keep off leaning surfaces during work operations
	Unscrew the cap slowly to let out the fuel vapours.		Static electricity can damage the parts on the circuit.
	Slowly unscrew the cooling liquid tap if the liquid must be topped up.		An electric shock can kill
	The vapor and the heated cooling liquid under pressure can burn face, eyes, skin.		
	Do not fill tank completely.		
	Wipe up spilled fuel before starting engine.		
	Shut off fuel of tank when moving machine (where it is assembled).		
Avoid spilling fuel on hot engine.			
Sparks may cause the explosion of battery vapours			



**FIRST AID.** In case the operator should be sprayed by accident, from corrosive liquids a/o hot toxic gas or whatever event which may cause serious injuries or death, predispose the first aid in accordance with the ruling labour accident standards or of local instructions.

Skin contact	Wash with water and soap
Eyes contact	Irrigate with plenty of water, if the irritation persists contact a specialist
Ingestion	Do not induce vomit as to avoid the intake of vomit into the lungs, send for a doctor
Suction of liquids from lungs	If you suppose that vomit has entered the lungs (as in case of spontaneous vomit) take the subject to the hospital with the utmost urgency
Inhalation	In case of exposure to high concentration of vapours take immediately to a non polluted zone the person involved



**FIRE PREVENTION.** In case the working zone, for whatsoever cause goes on fire with flames liable to cause severe wounds or death, follow the first aid as described by the ruling norms or local ones.

EXTINCTION MEANS	
Appropriated	Carbonate anhydride (or carbon dioxide) powder, foam, nebulized water
Not to be used	Avoid the use of water jets
Other indications	Cover eventual shedding not on fire with foam or sand, use water jets to cool off the surfaces close to the fire
Particular protection	Wear an autorespiratory mask when heavy smoke is present
Useful warnings	Avoid, by appropriate means to have oil sprays over metallic hot surfaces or over electric contacts (switches, plugs, etc.). In case of oil sprinkling from pressure circuits, keep in mind that the inflammability point is very low.

<b>WARNING</b>					<b>CAUTION</b>		<b>DANGEROUS</b>

 <b>WARNING</b>	<b>THE MACHINE MUST NOT BE USED IN AREAS WITH EXPLOSIVE ATMOSPHERE</b>
--------------------	--



**INSTALLATION AND ADVICE BEFORE USE**

**GASOLINE ENGINES**

- Use in open space, air swept or vent exhaust gases, which contain the deadly carbone oxyde, far from the work area.

**DIESEL ENGINES**

- Use in open space, air swept or vent exhaust gases far from the work area.

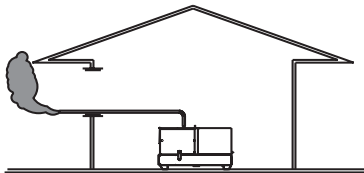
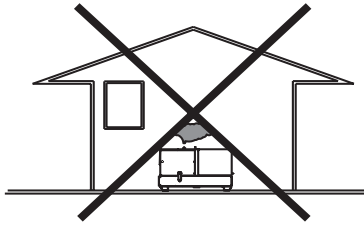

**POSITION**

Place the machine on a level surface at a distance of at least 1,5 m from buildings or other plants.

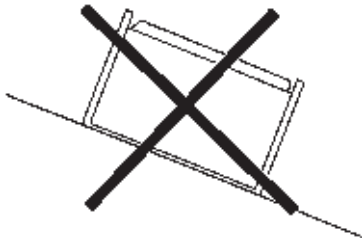

Maximum leaning of the machine (in case of dislevel)

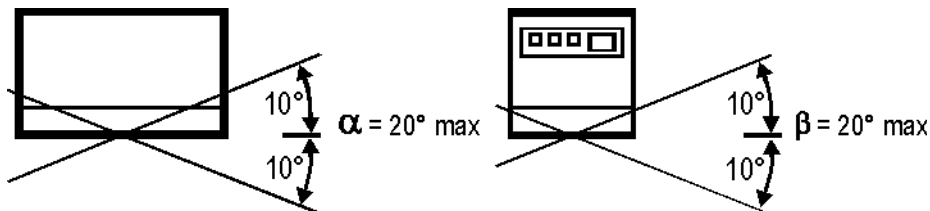

Check that the air gets changed completely and the hot air sent out does not come back inside the set so as to cause a dangerous increase of the temperature.

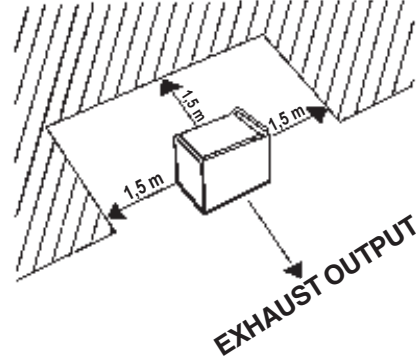

☞ Make sure that the machine does not move during the work: **block** it possibly with tools and/or devices made to this purpose.

**MOVES OF THE MACHINE**

☞ At any move check that the engine is **off**, that there are no connections with cables which impede the moves.

**PLACE OF THE MACHINE**

	<b>ATTENTION</b>
	For a safer use from the operator <b>DO NOT</b> fit the machine in locations with high risk of flood.
	Please do not use the machine in weather conditions which are beyond IP protection shown both in the data plate and on page named "technical data" in this same manual.

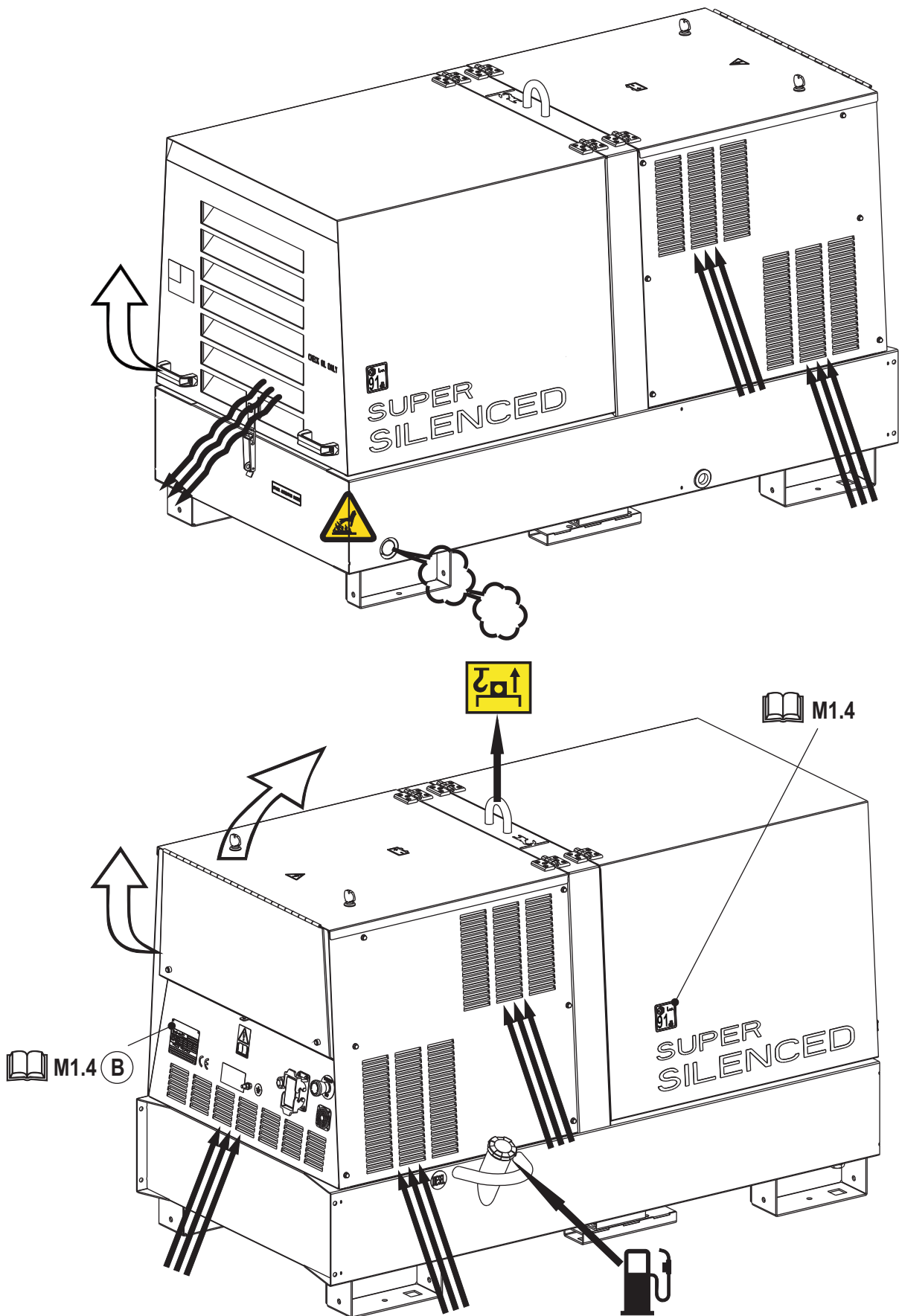



**NOTE**

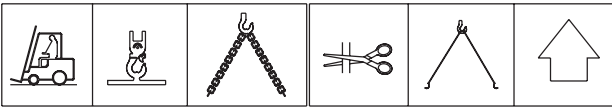

Be sure that the lifting devices are: correctly mounted, adequate for the weight of the machine with its packaging, and conforms to local rules and regulations.

When receiving the goods make sure that the product has not suffered damage during the transport, that there has not been rough handling or taking away of parts contained inside the packing or in the set.

In case you find damages, rough handling or absence of parts (envelopes, manuals, etc.), we advise you to inform immediately our Technical Service.



For eliminating the packing materials, the User must keep to the norms in force in his country.

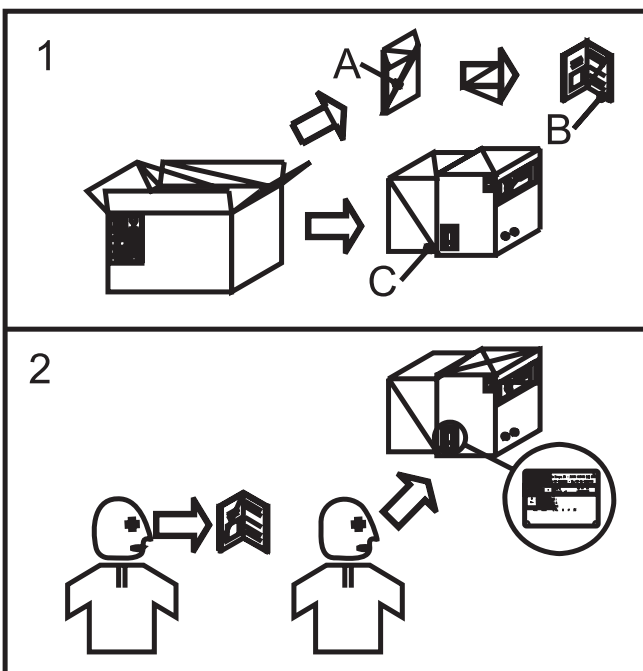
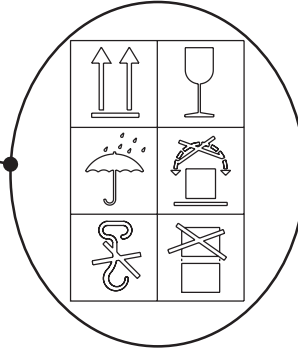
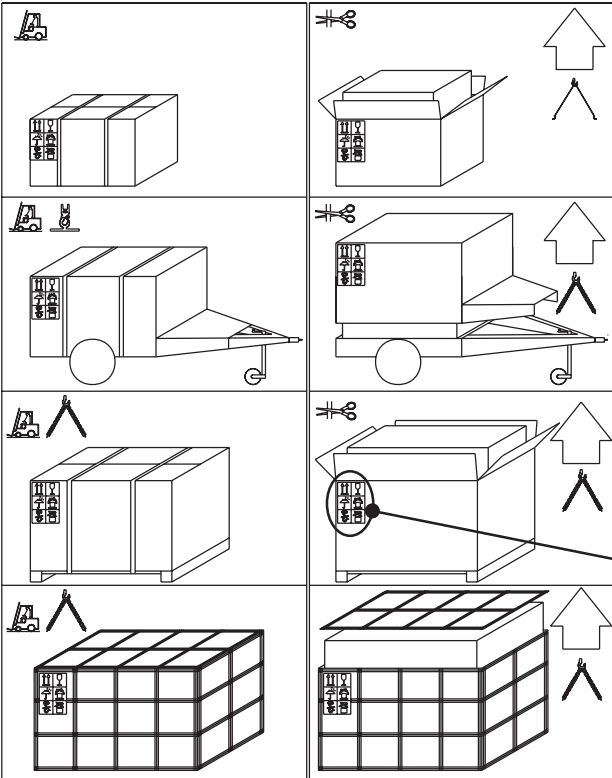

- 1) Take the machine (C) out of the shipment packing. Take out of the envelope (A) the user's manual (B).
- 2) Read: the user's manual (B), the plates fixed on the machine, the data plate.



**NOTE**

In case you should transport or move the machine, keep to the instructions as per the figures.

Make the transportation when the machine has **no** petrol in its tank, **no** oil in the engine and and electrolyte in the battery.

Be sure that the lifting devices are: correctly mounted, adequate for the weight of the machine with it's packaging, and conform to local rules and regulations.

Only authorized persons involved in the transport of the machine should be in the area of movement.

**DO NOT LOAD OTHER PARTS WHICH CAN MODIFY WEIGHT AND BARICENTER POSITION.**

**IT IS STRICTLY FORBIDDEN TO DRAG THE MACHINE MANUALLY OR TOW IT BY ANY VEHICLE (model with no CTL accessory).**

If you did not keep to the instructions, you could damage the structure of the machine.

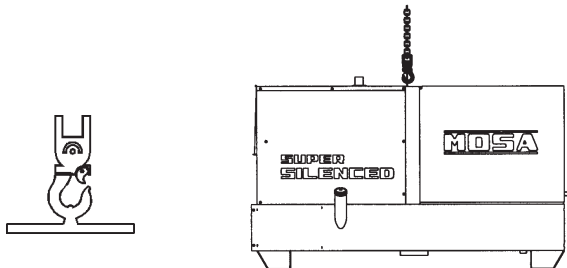
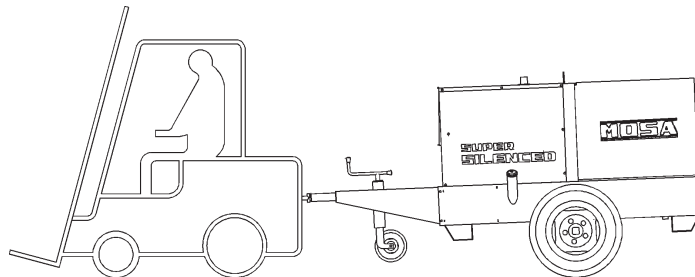
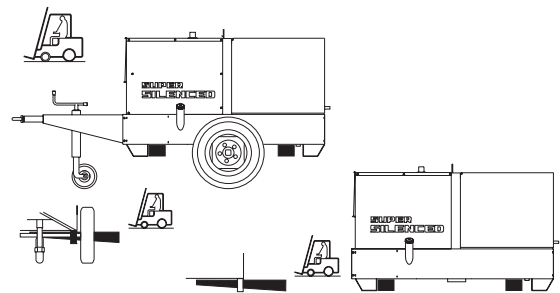
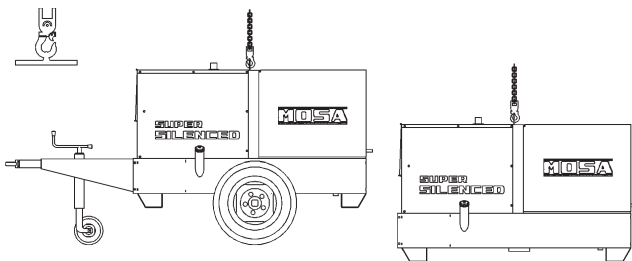

LIFT ONLY THE MACHINE

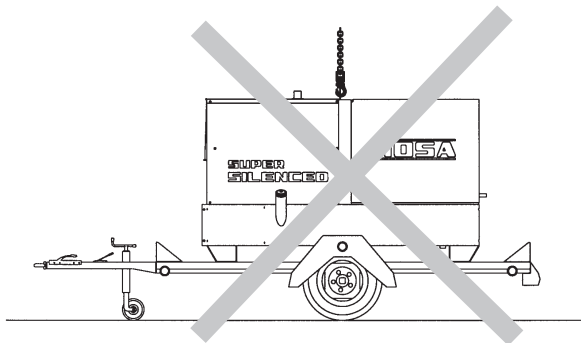

DO NOT LIFT THE MACHINE AND TRAILER



**DANGER: LIFTING EYE IS NOT DESIGNED TO SUPPORT ADDED WEIGHT OF ROAD TOW TRAILER**







## ATTENTION

The CTL accessory cannot be removed from the machine and used separately (actioned manually or following vehicles) for the transport of loads or anyway for used different from the machine movements.

### TRAILERS

The machines provided for assembling the CTL accessory (slow towing trolley) can be towed up to a **maximum** speed of **40 Kms/hour** on asphalted surfaces.

Towing on public roads or turnpikes of any type **IS EXCLUDED**, because **not** in possession of the requirements by national and foreign traffic norms.

**Nota:** Lift the machine and assemble the parts as shown in the drawing

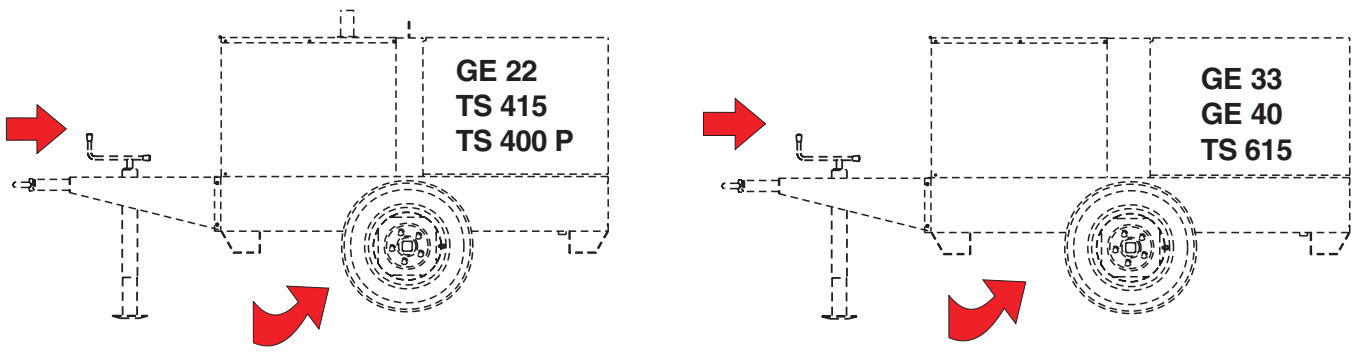

For assembling the generating set on the trolley CTL22 please keep to following instructions:

- 1) - Lift the generating set (by means of suitable hook).
- 6) - Assemble on the machine the towbar (5) complete of foot with the M10x20 screws, nuts and washers.
- 7) - Assemble the axle (7) to the base of the machine (see fig. page M6.3) with the M 10x25 screws and relative washers (two per part) so that their supports coincide.
- 8) - Insert the wheel (9) on the axle then screw the self blocking nuts (8).
- 9) - Pump the tyre (9) bringing the pressure to four atms.
- 10) - Lower the machine to the ground and place the parking foot definitively (regulating at the best height).

**ATTENTION**

Do not substitute the original tires with other types.

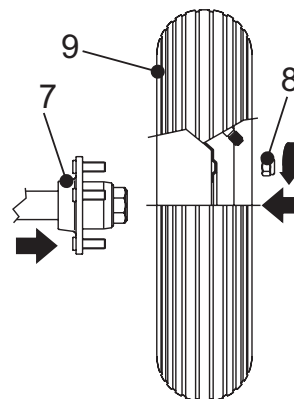
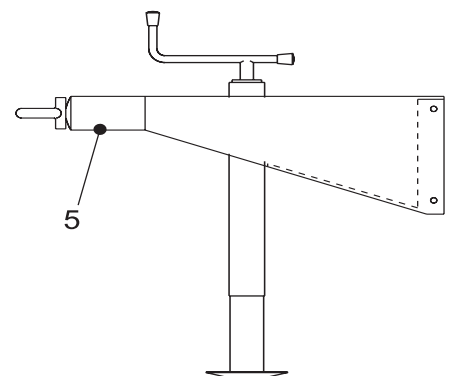



**BATTERY WITHOUT MAINTENANCE**



Connect the cable + (positive) to the pole + (positive) of the battery (after having taken away the protection), by properly tightening the clamp.

Check the state of the battery from the colour of the warning light which is in the upper part.

- Green colour: battery OK
  - Black colour: battery to be recharged
  - White colour: battery to be replaced
- DO NOT OPEN THE BATTERY.**



**LUBRICANT**

**RECOMMENDED OIL**

MOSA recommends selecting **AGIP** engine oil. Refer to the label on the motor for the recommended products.

<p>PRODOTTI RACCOMANDATI RECOMMENDED PRODUCTS</p>	
<p><b>AGIP</b> SUPERDIESEL 15W/40 API CF4-SG</p>	<p>OLIO MOTORE DIESEL DIESEL ENGINE OIL</p> <input type="checkbox"/>
<p><b>AGIP</b> SUPERMOTOROIL 20W/50 API CC-SF</p>	<p>OLIO MOTORE BENZINA GASOLINE ENGINE OIL</p> <input type="checkbox"/>
<p><b>AGIP</b> ANTIFREEZE EXTRA INIBITE ETHYLENE GLYCOL (50% + 50% H<sub>2</sub>O)</p>	<p>CIRCUITO DI RAFFREDDAMENTO COOLING CIRCUIT (CUNA NC 956-16 ED 97)</p> <input type="checkbox"/>

Please refer to the motor operating manual for the recommended viscosity.

**REFUELLING AND CONTROL:**

Carry out refuelling and controls with motor at level position.

1. Remove the oil-fill tap (24)
2. Pour oil and replace the tap
3. Check the oil level using the dipstick (23); the oil level must be comprised between the minimum and maximum indicators.



**AIR FILTER**

Check that the dry air filter is correctly installed and that there are no leaks around the filter which could lead to infiltrations of non-filtered air to the inside of the motor.



**FUEL**

**ATTENTION**

Do not smoke or use open flames during refuelling operations, in order to avoid explosions or fire hazards.

Fuel fumes are highly toxic; carry out operations outdoors only, or in a well-ventilated environment.

Avoid accidentally spilling fuel. Clean any eventual leaks before starting up motor.

Refill the tank with good quality diesel fuel, such as automobile type diesel fuel, for example.

For further details on the type of diesel fuel to use, see the motor operating manual supplied.

Do not fill the tank completely; leave a space of approx. 10 mm between the fuel level and the wall of the tank to allow for expansion.

In rigid environmental temperature conditions, use special winterized diesel fuels or specific additives in order to avoid the formation of paraffin.

**ATTENTION**

It is dangerous to fill the motor with too much oil, as its combustion can provoke a sudden increase in rotation speed.



**COOLING LIQUID****ATTENTION**

Do not remove the radiator tap with the motor in operation or still hot, as the liquid coolant may spurt out and cause serious burns. Remove the tap very carefully.

Remove the tap and pour the liquid coolant into the radiator; the quantity and composition of the liquid coolant are indicated in the motor operating manual. Replace the tap, ensuring it is perfectly closed.

After refilling operations, allow the motor to run for a brief time and check the level, as it may have diminished due to air bubbles present in the cooling circuit; restore the level with water.

To replace the liquid coolant, follow the operations described in the motor operating manual.

**GROUNDING CONNECTION**

The grounding connection to an earthed installation **is obligatory** for all models equipped with a differential switch (circuit breaker). In these groups the generator star point is generally connected to the machine's earthing; by employing the TN or TT distribution system, the differential switch guarantees protection against indirect contacts.

In the case of powering complex installations requiring or employing additional electrical protection devices, the coordination between the protection devices must be verified.

For the grounding connection, use the terminal (12); comply to local and/or current regulations in force for electrical installations and safety.





Check daily



**NOTE**

*Do not alter the primary conditions of regulation and do not touch the sealed parts.*

The starting of the unit can be effected in 3 different modes:

**1) Start with EP6 key (Engine Control)**

Put the “Local/Remote” selector on Local. Turn the key on “ON”, the EP6 display shows only on the machines with mounted glow plugs for 5 secs, the symbol “UUUU”, then the message “Sta” appears the engine can be started, for which turn the key on “start” and start the engine.

On the display the word “Sta” remains for about 20 secs then automatically disappears; the engine **must be** started within 20 secs, otherwise the EP6 blocks the starting and on the display the word “fail” appears. Turning the key on “OFF” the EP6 is reset and a new starting cycle can be fixed.

**Stop:**

it is **COMPULSORY** to disconnect the load first, then to stop the engine turn the key on “OFF”.

**2) Remote starting with TCM35**

Put the “Local/Remote” selector on Local. Connect TCM35 to the plug on the front panel and put the switch on “0”.

Turn the key on ON in the EP6 (Engine Control), wait for the various signals to go out then press the button “AUTO” in the EP6 until the led “AUTO” flashes.

Shift the switch on “I” in the TCM35 and automatically the starting cycle will start. On the machines with mounted glow plugs appears in the display EP6 (for about 5 secs), the symbol “UUUU”; the starting cycle includes 3 starting trials.

When the engine starts the led “AUTO” remains lit continuously and simultaneously the red warning light will light in the TCM35.

**Stop:**

it is **COMPULSORY** to disconnect the load first, then shift the switch of the TCM35 on “0”, the engine will stop immediately.

**3) Start with Automatic start unit (EAS)**

Put the “Local/Remote” selector on Remote. Connect the EAS to unit.

The EAS controls the starting as well as the stop of the engine.

Follow attentively the instructions reported in the EAS manual. In these conditions the EP6 has the only function to measure the electric values, hour-meter, etc.



**CAUTION**

**MACHINE WITH EMERGENCY BUTTON**

Pressing the button the engine will stop immediately in any working condition.

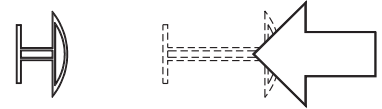

Turn clockwise to reset the button.

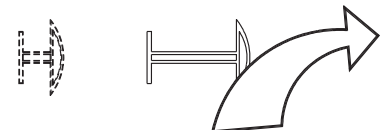

**CAUTION**

**RUNNING-IN**

*During the first 50 hours of operation, do not use more than 60% of the maximum output power of the unit and check the oil level frequently, in any case please stick to the rules given in the engine use manual.*



**NOTE**

For safety reason the key must be kept by qualified personel.

4A	Hydraulic oil level light	A4	Button indicating light 30 I/1' PTO HI	W5	Battery voltmeter
9	Welding socket ( + )	B2	Engine control unit EP2	X1	Remote control socket
10	Welding socket ( - )	B3	E.A.S. connector	Y3	Button indicating light 20 I/1' PTO HI
12	Earth terminal	B4	Exclusion indicating light PTO HI	Y5	Commutator/switch, serial/parallel
15	A.C. socket	B5	Auxiliary current push button	Z2	Thermal-magnetic circuit breaker
16	Accelerator lever	C2	Fuel level light	Z3	Selection push button 20 I/1' PTO HI
17	Feed pump	C3	E.A.S. PCB	Z5	Water temperature indicator
19	48V D.C. socket	C6	Control unit for generating sets QEA		
22	Engine air filter	D	Ground fault interrupter ( 30 mA )		
23	Oil level dipstick	D1	Engine control unit and economiser EP1		
24	Engine oil reservoir cap	D2	Ammeter		
24A	Hydraulic oil reservoir cap	E2	Frequency meter		
24B	Water filling cap	F	Fuse		
25	Fuel prefilter	F3	Stop switch		
26	Fuel tank cap	F5	Warning light, high temperature		
27	Muffler	F6	Arc-Force selector		
28	Stop control	G1	Fuel level transmitter		
29	Engine protection cover	H2	Voltage commutator		
30	Engine cooling/alternator fan belt	H6	Fuel electro pump		
31	Oil drain tap	H8	Engine control unit EP7		
31A	Hydraulic oil drain tap	I2	48V A.C. socket		
31B	Water drain tap	I3	Welding scale switch		
31C	Exhaust tap for tank fuel	I4	Preheating indicator		
32	Button	I5	Y/▲ switch		
33	Start button	I6	Start Local/Remote selector		
34	Booster socket 12V	I8	AUTOIDLE switch		
34A	Booster socket 24V	L	A.C. output indicator		
35	Battery charge fuse	L5	Emergency button		
36	Space for remote control	L6	Choke button		
37	Remote control	M	Hour counter		
42	Space for E.A.S.	M1	Warning level light		
42A	Space for PAC	M2	Contactora		
47	Fuel pump	M5	Engine control unit EP5		
49	Electric start socket	M6	CC/CV switch		
54	Reset button PTO HI	N	Voltmeter		
55	Quick coupling m. PTO HI	N1	Battery charge warning light		
55A	Quick coupling f. PTO HI	N2	Thermal-magnetic circuit breaker/ Ground fault interrupter		
56	Hydraulic oil filter		Pre-heat push-button		
59	Battery charger thermal switch	N5	Connector - wire feeder		
59A	Engine thermal switch	O1	Oil pressure warning light/Oil alert		
59B	Aux current thermal switch	P	Welding arc regulator		
59C	Supply thermal switch wire feeder- 42V	Q1	Starter key		
59D	Pre-heater (spark plug) thermal switch	Q3	Derivation box		
59E	Supply thermal switch oil/water heater	Q4	Battery charge sockets		
59F	Electropump thermal switch	Q7	Welding selector mode		
63	No load voltage control	R3	Siren		
66	Choke control	S	Welding ammeter		
67A	Auxiliary / welding current control	S1	Battery		
68	Cellulosic electrodes control	S3	Engine control unit EP4		
69A	Voltmeter relay	S6	Wire feeder supply switch		
70	Warning lights	S7	Plug 230V singlephase		
71	Selecting knob	T	Welding current regulator		
72	Load commut. push button	T4	Dirty air filter warning light/indicator		
73	Starting push button	T5	Earth leakage relay		
74	Operating mode selector	T7	Analogic instrument V/Hz		
75	Power on warning light	U	Current transformer		
76	Display	U3	R.P.M. adjuster		
79	Wire connection unit	U4	Polarity inverter remote control		
86	Selector	U5	Release coil		
86A	Setting confirmation	U7	Engine control unit EP6		
87	Fuel valve	V	Welding voltage voltmeter		
88	Oil syringe	V4	Polarity inverter control		
A3	Insulation monitoring	V5	Oil pressure indicator		
		W1	Remote control switch		
		W3	Selection push button 30 I/1' PTO HI		

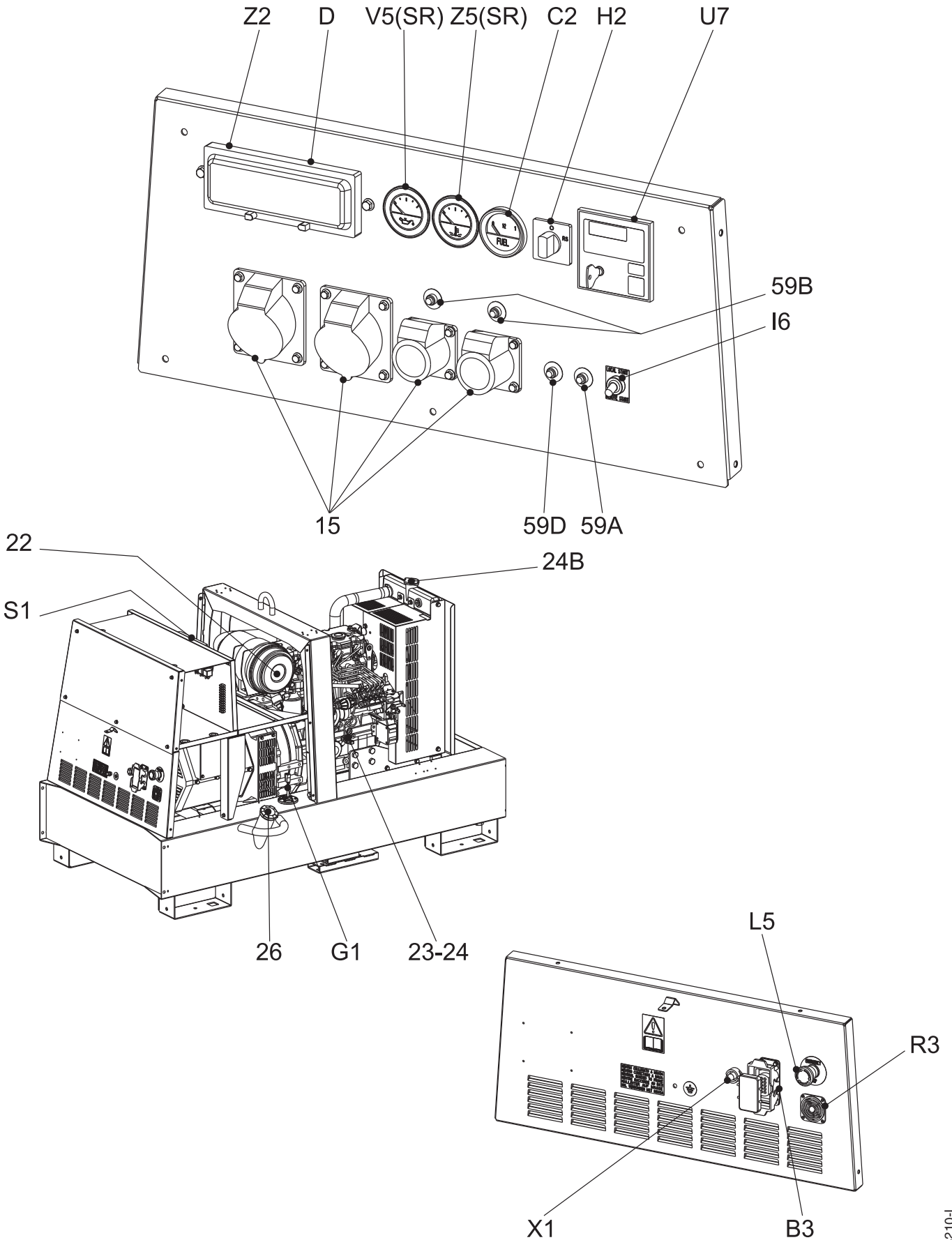





## WARNING

***It is absolutely forbidden to connect the unit to the public mains and/or another electrical power source .***



**Access forbidden to area adjacent to electricity-generating group for all non-authorized personnel.**

The electricity-generating groups are to be considered electrical energy producing stations.

The dangers of electrical energy must be considered together with those related to the presence of chemical substances (fuels, oils, etc.), rotating parts and waste products (fumes, discharge gases, heat, etc.).

### GENERATION IN AC (ALTERNATING CURRENT)

Before each work session check the efficiency of the ground connection for the electricity-generating group if the distribution system adopted requires it, such as, for example, the TT and TN systems.

Check that the electrical specifications for the units to be powered - voltage, power, frequency - are compatible with those of the generator. Values that are too high or too low for voltage and frequency can damage electrical equipment irreparably.

In some cases, for the powering of three-phase loads, it is necessary to ensure that the cyclic direction of the phases corresponds to the installation's requirements.

Connect the electric devices to be powered to the AC sockets, using suitable plugs and cables in prime condition.

Before starting up the group, make certain no dangerous situations exist on the installation to be powered.

Check that the thermal-magnetic switch (Z2) is in the OFF position (input lever in downward position).

Start up the electricity-generating group, positioning the thermal-magnetic switch (Z2) and differential switch (D) to ON (input lever in upward position).

Before powering on the utilities, check that the voltmeter (N) and frequency meter (E2) indicate nominal values; in addition, check on the voltmeter change-over switch (H2) (where it is assembled) that the three line voltages are the same.

In the absence of a load, the values for voltage and frequency can be greater than their nominal values. See sections on VOLTAGE and FREQUENCY.

### OPERATING CONDITIONS

#### POWER

The electrical power expressed in kVA on an electricity-generating group is the available output power to the reference environmental conditions and nominal values for: voltage, frequency, power factors (cos φ).

There are various types of power: PRIME POWER (PRP), STAND-BY POWER established by ISO 8528-1 and 3046/1 Norms, and their definitions are listed in the manual's TECHNICAL SPECIFICATIONS page.

During the use of the electricity-generating group **NEVER EXCEED** the power indications, paying careful attention when several loads are powered simultaneously.

### VOLTAGE

#### GENERATORS WITH COMPOUND SETTING.

In these types of generators, the no-load voltage is generally greater than 3–5% with respect to its nominal value; f.e. for nominal voltage, threephase 400Vac or singlephase 230Vac, the no-load voltage can be comprised between 410-420V (threephase) and 235-245V (singlephase). The precision of the load voltage is maintained within ±5% with balanced loads and with a rotation speed variation of 4%. Particularly, with resistive loads (cos φ = 1), a voltage over-elevation occurs which, with the machine cold and at full load, can even attain +10 %, a value which in any case is halved after the first 10-15 minutes of operation.

The insertion and release of the full load, under constant rotation speed, provokes a transitory voltage variation that is less than 10%; the voltage returns to its nominal value within 0.1 seconds.

#### GENERATORS WITH ELECTRONIC SETTING (A.V.R.).

In these types of generators, the voltage precision is maintained within ±1,5%, with speed variations comprised from -10% to +30%, and with balanced loads. The voltage is the same both with no-load and with load; the insertion and release of the full load provokes a transitory voltage variation that is less than 15%; the voltage returns to its nominal value within 0.2–0.3 seconds.

### FREQUENCY

The frequency is a parameter that is directly dependent on the motor's rotation speed. Depending on the type of alternator, 2 or 4 pole, we will have a frequency of 50/60 Hz with a rotation speed of 3000/3600 or 1500/1800 revolutions per minute.

The frequency, and therefore the number of motor revolutions, is maintained constant by the motor's speed regulation system.

Generally, this regulator is of a mechanical type and presents a droop from no-load to nominal load which is less than 5 % (static or droop), while under static conditions precision is maintained within ±1%. Therefore, for generators at 50Hz the no-load frequency can be 52–52.5 Hz, while for generators at 60Hz the no-load frequency can be 62.5-63Hz.





In some motors or for special requirements the speed regulator is electronic; in these cases, precision under static operating conditions attains  $\pm 0.25\%$ , and the frequency is maintained constant in operation from no-load to load (isochronal operation).

**POWER FACTOR - COS  $\phi$**

The power factor is a value which depends on the load's electrical specifications; it indicates the ratio between the Active Power (kW) and Apparent Power (kVA). The apparent power is the total power necessary for the load, achieved from the sum of the active power supplied by the motor (after the alternator has transformed the mechanical power into electrical power), and the Reactive Power (kVAR) supplied by the alternator. The nominal value for the power factor is  $\cos \phi = 0,8$ ; for different values comprised between 0.8 and 1 it is important during usage not to exceed the declared active power (kW), so as to not overload the electricity-generating group motor; the apparent power (kVA) will diminish proportionally to the increase of  $\cos \phi$ .

For  $\cos \phi$  values of less than 0.8 the alternator must be downgraded, since at equal apparent power the alternator should supply a greater reactive power. For reduction coefficients, contact the Technical Service Department.

**START-UP OF ASYNCHRONOUS MOTORS**

The start-up of asynchronous motors from an electricity-generating group can prove critical because of high start-up currents the asynchronous motor requires (I start-up = up to 8 times the nominal current  $I_n$ ). The start-up current must not exceed the alternator's admissible overload current for brief periods, generally in the order of 250–300% for 10–15 seconds.

To avoid a group oversize, we recommend following these precautionary measures:

- in the case of a start-up of several motors, subdivide the motors into groups and set up their start-up at intervals of 30–60 seconds.
- when the operating machine coupled to the motor allows it, see to a start-up with reduced voltage, star point/triangle start-up or with autotransformer, or use a soft-start system.

In all cases, when the user circuit requires the start-up of an asynchronous motor, it is necessary to check that there are no utilities inserted into the installation, which in the case of a voltage droop can cause more or less serious disservices (opening of contact points, temporary lack of power to control and command systems, etc.).

**SINGLE-PHASE LOADS**

Power to monophasic utilities by means of three-phase generators requires some operating limitations.

- In single-phase operation, the declared voltage tolerance can no longer be maintained by the regulator (compound or electronic regulator), since the system becomes highly unbalanced. **The voltage variation on the phases not affected by the power can prove dangerous; we recommend sectioning the other loads eventually connected.**

- The maximum power which can be drawn between Neutral and Phase (start connection) is generally 1/3 of the nominal three-phase power; some types of alternators even allow for 40%. Between two Phases (triangle connection) the maximum power cannot exceed 2/3 of the declared three-phase power.
- In electricity-generating groups equipped with monophasic sockets, use these sockets for connecting the loads. In other cases, always use the "R" phase and Neutral.

**ELECTRIC PROTECTIONS**

**THERMAL-MAGNETIC SWITCH**

The electricity-generating group is protected against short-circuits and against overloads by a thermal-magnetic switch (Z2) situated upstream from the installation. Operating currents, both thermic and magnetic, can be fixed or adjustable in relation to the switch model.

In models with adjustable operating current **do not modify** the settings, since doing so can compromise the installation's protection or the electricity-generating group's output characteristics. For eventual variations, contact our Technical Service Department.

The intervention of the protection feature against overloads is not instantaneous, but follows a current overload/time outline; the greater the overload the less the intervention.

Furthermore, keep in mind that the nominal operating current refers to an operating temperature of 30°C, so that each variation of 10°C roughly corresponds to a variation of 5% on the value of nominal current.

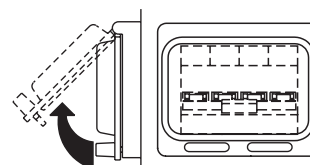

In case of an intervention on the part of the thermal magnetic protection device, check that the total absorption does not exceed the electricity-generating group's nominal current.



**DIFFERENTIAL SWITCH**

The differential switch or differential relay guarantee protection against indirect contacts due to malfunction currents towards the ground. When the device detects a malfunction current that is higher than the nominal current or the set current, it intervenes by cutting off

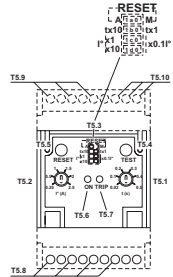
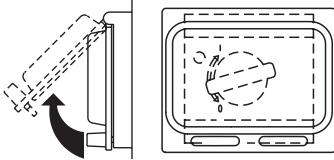

power to the circuit connected.

In the case of an intervention by the differential switch, check that there are no sheathing defects in the installation: connection cables, sockets and plugs, utilities connected.

Before each work session, check the operation of the differential protection device by pressing the test key. The electricity-generating group must be in operation, and the lever on the differential switch must be in the ON position.

**THERMIC PROTECTION**

Generally present to protect against overloads on an individual power socket c.a.

When the nominal operating current has been exceeded, the protection device intervenes by cutting off power to the socket.

The intervention of the protection device against overloads is not instantaneous, but follows a current overload/time outline; the greater the overload the less the intervention.

In case of an intervention, check that the current absorbed by the load does not exceed the protection's nominal operating current.

Allow the protection to cool off for a few minutes before resetting by pressing the central pole.



**USAGE WITH EAS AUTOMATIC START-UP PANEL**

The electricity-generating group in combination with the EAS automatic start-up panel forms a unit for distributing electrical energy within a few seconds of a power failure from the commercial electrical power line.

Below is some general operating information; refer to the automatic panel's specific manual for details on installation, command, control and signalling operations.

- Perform connections on the installation in safety conditions. Position the automatic panel in RESET or LOCKED mode.
- Carry out the first start-up in MANUAL mode. Check that the generator's LOCAL START / REMOTE START switch (I6) is in the REMOTE position. Check that the generator switches are enabled (input lever in upward position).

Position the EAS panel in manual mode by pressing MAN. key, and only after having checked that there are no dangerous situations, press the START key to start the electricity-generating group.

- During the operation of the generator, all controls and signals from both the automatic panel and group are enabled; it is therefore possible to control its operation from both positions.

In case of an alarm with a shutdown of the motor (low pressure, high temperature, etc.), the automatic panel will indicate the malfunction that has caused the stoppage, while the generator's front panel will be disabled and will no longer supply any information.

**ATTENTION**

*Do not keep the central pole on the thermic protection forcefully pressed to prevent its intervention.*



**MAKE SURE**

- The selector LOCAL START/REMOTE START (I6) of the generating set must be switched on LOCALSTART.
- Put the selector „switch board (N7)“ on ON.

The coupling of the TCM 35 with the generating set, ready for remot starting, permits to work far from the set itself.

The remote control is connected to the front plate (X1), and/or rear plate, with a multiple connector.

**N.B.** The remote control TCM 35 can be used only with machines equipped with control and protection device EP6 (U7).

For use of TCM 35 see page M21 (start and stop) of this manual.

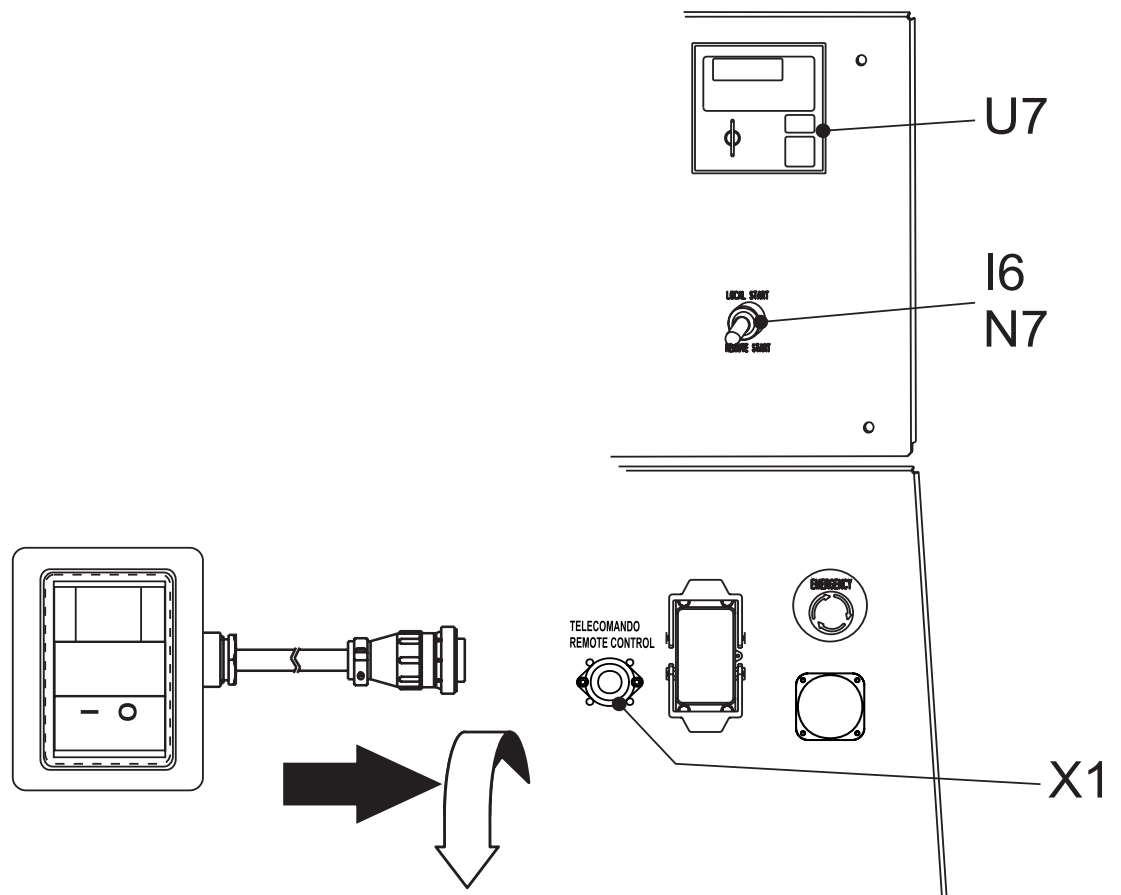

## EP6 OEM's Manual - Contents

1.0 Introduction	M39.12
2.0 Operating Mode selection	M39.12
2.1 AUTO operating mode	M39.12
2.2 MANUAL operating mode	M39.12
2.3 OFF operating mode	M39.12
3.0 DISPLAY features	M39.12
4.0 ALARM messages	M39.12.1
4.1 Operating Messages	M39.12.1
5.0 LEDs for visual indication	M39.12.1
5.1 LEDs and Display Test	M39.12.1
6.0 Parameters and Settings	M39.12.1
7.0 Remote Start	M39.12.4
8.0 Safety	M39.12.4
9.0 Automatic Periodic Test	M39.12.4
10.0 Front Panel Description	M39.12.4
11.0 Dimensions and Rear View	M39.12.4

### 1.0 INTRODUCTION

The EP6 features Engine and Generating Set control and monitoring. The EP6 provides visual indication by means of LEDs (solid state lamps) and a Display (see section 10.0). It features OFF, MAN and AUTO operating modes. The display gives Messages for alarms and Measurement indications.

### 2.0 OPERATING MODE selection

The EP6 features AUTO (section 2.1), MANUAL (section 2.2) and OFF (section 2.3) operating modes. When the power supply is switched on, the EP6 behaves as follow:

- A) if the KEY-SWITCH is in the **OFF position**, the EP6 enters the OFF operating mode.
- B) if the KEY-SWITCH is in the **ON position**, the EP6 enters the AUTO operating mode. That is, if the EP6 was in AUTO prior to the supply removal. If not, the EP6 enters the MANUAL operating mode.

### 2.1 AUTO operating mode

To enter the 'AUTO' operating mode use the following instructions:

- A) - Turn ON the key switch: the Display and LEDs illuminate for 1 second.
- B) - Wait for the end of the LAMP test, then push the AUTO pushbutton after the [UUUU] (Pre-glow) or [Sta-] (Start prompt) has been displayed. After this, the yellow Led AUTO will illuminate. If the REMOTE START input is not operative, the LED will flash. If operative, the LED illuminates continuously and a start cycle will take place (**NOTE**: the EP6 shuts down the display during the crank).
- C) - In order to cancel the AUTO operating mode,

push the AUTO pushbutton (the yellow Led will turn OFF) or turn the KEY-SWITCH to OFF.

Once in AUTO, the EP6 waits for a REMOTE START activation (see section 7.0).

In case of an Automatic Periodic Test (A.P.T.), the display will show the message [tEst].

### 2.2 MANUAL operating mode

To start the engine follow the instructions:

- A) - Turn ON the KEY-SWITCH; the EP6 illuminates the LEDs and Display.
- B) - If the display shows the message [uuuu], the EP6 is counting the PRE-GLOW time; wait until the message disappears.
- C) - After the display shows the flashing message [StA-] (**NOTE**), turn the Key to START position (momentary position with spring-loaded return) until the engine starts. The message [ . . . ] indicates a MANUAL start.
- D) - To stop the engine, turn the KEY SWITCH to OFF.

**NOTE: EP6 shows the blinking [StA-] message for 20 seconds. After this time, if the engine does not start, the EP6 displays the message [FAIL] (Fail to start, see section 4.07). To clear the alarm, turn the KEY-SWITCH to OFF.**

### 2.3 OFF operating mode

This function is obtained by turning the KEY SWITCH to OFF. The OFF operating mode clears the fault alarms and shuts down the Display after 5 seconds. A blinking dot indicates the presence of the power supply. Press one of the pushbuttons to energize the display. In OFF operating mode, the EP6 allows reading of the parameters (see section 6.0)

### 3.0 DISPLAY features

The EP6 features a 4 Digit Display (section 10.0) to show measurements, settings and error messages. The [UP-DOWN] pushbutton selects one of the following menus:

[Axxx] (\*) Generator Current measurement  
 [Uxxx] The Voltage of the Generating Set  
 [rPM] [xxxx ] Speed of the engine  
 [Hxx.X] Frequency of the Generator  
 [bxx.X] Battery Voltage.  
 [cxx.X] Charger Alternator Voltage  
 [ h ] [xxxx ] HOUR METER (the message [h] appears for a moment, and then, the counter will be displayed continuously)

(\*): the symbol 'X' means a numerical field.

#### 4.0 ALARM messages

The alarms are displayed by means of messages. In case of alarm consult your Generating Set manufacturer. To remove the message, turn OFF the KEY-SWITCH. The EP6 may show one of the following:

[OIL]	Low Oil Pressure
[ °C ]	High Temperature
[O.SPd.]	Over Speed of the engine
[U.SPd]	Under Speed of the engine
[bELt]	Failure of the belt
[ALAr]	External Emergency Stop
[FUEL](1)	Low Fuel in the tank
[FAIL] (3)	Starting Failure Alarm
[E 05](2)	Generator Overload
[Hi H](2)	Generator Over Frequency
[Lo H](2)	Generator Under Frequency
[Hi U] (2)	Generator Under Voltage
[Lo U](2)	Generator Under Voltage
[XX.X]	Battery Voltage
[Err ]	Memory error
[E 04]	Alternator Failure

(1) [FUEL] This message indicates Low Fuel in the tank . The engine stops if the contacts remain closed for 5 minutes continuously. To clear the alarm, follow the instructions:

- turn OFF the key switch - b) fill the tank
- turn ON the key to display the message [FULL]
- turn OFF the key in order to cancel the alarm
- turn ON the key to select the MANUAL or AUTO operating mode

(2) To determine the value that caused the failure, push the [F1] pushbutton.

#### 4.1 OPERATING messages

EP6 features messages to inform you about the following:

[uuuu]	Glow-plugs timing
[U— ]	Voltage out of range
[StA-]	Start prompt
[. . . ]	Starting by key switch
[rESt]	Rest timing
[tESt]	Automatic Test
[CAL]	Calibration
[Pro-]	Programming
[rEAd]	Parameter reading
[StOP]	Stopping cycle
[MM.SS]	Remote Start or Remote Stop cycle

#### 5.0 LEDs for visual indication

The EP6 features two LEDs (see section 10.0) to indicate the following conditions:

[ENGINE RUNNING]: this green led illuminates when the engine is running.

[AUTO]: this yellow LED blinks to indicate a standby mode. The EP6 monitors the REMOTE CONTROL and expects a command. The LED illuminates continuously when the REMOTE START is activated.

#### 5.1 LEDs and Display Test

A test of the LEDs and DISPLAY is obtained automatically anytime the key switch is turned ON. The LEDs and DISPLAY light up for about 1 second.

#### 6.0 Parameters and settings

The unit is programmed by the supplier of the Generating Set. Contact the Generator manufacturer in order to have the permission to program the module. It is possible to read the status of the internal programming at anytime. Follow the instructions:

- Turn the Key in OFF (if the display indicates [STOP], wait until it disappears)
- Push and hold the [F1] pushbutton until the message [rEAd] appears (10 secs).
- Release the button; the display will show the first programmable parameter ([P.0]).
- Push the [F1] pushbutton: the display will indicate the value of the parameter ([ 1"]).
- Push the [UP-DOWN] pushbutton to select a parameter ([P.0] to [P.29]). Push [F1] to display the setting.
- The display returns to menu mode if you have not used the pushbuttons for 30 seconds.

The list of the parameters follows ([,] means minutes and [,] means seconds). Some parameters may differ according to the programming done by the genset manufacturer.



Display	Parameter [Default]
[P.0]	<b>Remote Start Delay Timing (Input #7) [ 1"]</b> Range: 1-59 secs or 1-15 mins Seconds or minutes of continuous REMOTE START command to initiate the automatic engine start (see section 7.0 and [P20] in this section).
[P.1]	<b>Remote Stop Delay Timing (Input #7) [ 1"]</b> Range: 1-59 secs or 1-15 mins Seconds or minutes of continuous absence of the REMOTE START command to initiate the stop cycle (see section 7.0 and [P.20] in this section).
[P.2]	<b>Crank Timing (Output #10) [ 5"]</b> Range: 1-20 seconds Maximum insertion time of the <i>Starter Motor</i> .
[P.3]	<b>Engine Running Trigger (Input#1) [ 8.0]</b> Range: 3V-24V,[inh] If the voltage of the Charger Alternator rises above the [setting], the <i>Starter Motor</i> is disconnected.
[P.4]	<b>Rest Timing [ 3"]</b> Range: 3-20 secs. Time interval between starting attempts
[P. 5]	<b>Starting Attempts [ 3 ]</b> Range: 1-10 This parameter sets the number of attempts in the automatic start cycle
[P.6]	<b>Generator UnderVoltage, short-circuit [ inh.]</b> Range: 80-400V. If the voltage drops under the [setting] for at least 6 secs, or under [setting]-20% for 1 sec, the Under-Voltage protection [Lo U] will shut down the engine.
[P.7]	<b>Generator Over-Voltage [500V]</b> Range: 110-550V or [inh.]. If the Generator voltage rises above the [setting] for at least 2 seconds, the EP6 will energize the over voltage protection [Hi U] (see section 4.0) to stop the engine. The [inh.] code inhibits the over voltage.
[P.8]	<b>Generator Under-Frequency [Inh.]</b> [inh.] 1 to 99Hz ([inh]=disables the under frequency) This protection is delayed by about 6 seconds. The EP6 shuts down the engine and the display will show the [Lo H] message.
[P.9]	<b>Generator Over-Frequency [55]</b> 45 Hz to [inh.] ([inh.] disables the over frequency) This protection is delayed by about 2 seconds. The EP6 shuts down the engine and displays [Hi H]
[P.10]	<b>Current Transformer Size [...]</b> The range is 10/5 up to 1000/5
[P.11]	<b>Generator Overload Setting [inh.]</b> Range: [inh.] to 1000 A The EP6 shuts down the engine after a delay of 6 secs and shows the message [E05].
[P.12][OFF]	<b>Generator Failure Alarm</b> selection: [on] or [OFF]. The code [on] enables the <i>Generator</i> failure alarm. The EP6 shows the [E04] message and the engine will shut down.
[P.13]	<b>Glow Plugs/Choke Control (Output #11) [ 5"]</b> Range: 1 to 99 secs. The EP6 energizes the output #11 for the programmed time.
[P.14]	<b>Output Control [ 0 ]</b> The following options are available: [ 0] None [ 1] Choke Control [ 2] Glow Plugs Control [ 3] Choke Control
[P.15]	<b>Belt Break Control [ON]</b> Selection: [on] or [OFF]. The Belt Break alarm is indicated by means of the message [bELt]

- [P.16] **Stop Solenoid Timing [ 2"]**  
Range: 2-99 secs. Duration of the Stop cycle.
- [P.17] **Alarm Output Timing [ 1']**  
[inh.]-59 secs 1-15 mins and [cont]. Time-out of the alarm output. The code [cont] disables the time-out, and the alarm remains energized until the OFF operating mode is selected. The [inh.] mode enables the use of the external contactor
- [P.18] **Temperature Switch [n.o.]**  
Selection: [n.o.] or [n.c.]  
[n.o.] the engine shuts down if the contact closes  
[n.c.] the engine shuts down if the contact opens
- [P.19] **ALARM Control [n.c.]**  
Selection: [n.o.] or [n.c.]  
[n.o.] the engine shuts down if the contact closes  
[n.c.] the engine shuts down if the contact opens
- [P.20] **Remote Start [n.o.]**  
Selection: [n.o.] or [n.c.]  
[n.o.] the engine starts if the contact closes  
[n.c.] the engine starts if the contact opens
- [P.21] **Under Speed setting [Inh.]**  
[Inh.] or 100-4000 r.p.m..The [Inh.] code disables the Under Speed shut down.
- [P.22] **Over Speed setting [Inh.]**  
100-4000 rpm or [Inh.]. The EP6 provides one second bypass delay. The [Inh.] code (>4000 r.p.m.) disables the Over Speed shut down.
- [P.23] **Number of Teeth of the Flywheel [Inh.]**  
[Inh.] or 1-500 teeth.  
The [Inh.] code disables the reading of the Speed (section 3.0), the Over/Under Speed alarms, and the Crank termination (see [P.24]).
- [P.24] **Crank OFF [Inh.]**  
Crank Termination setting: 100-800 rpm  
If the speed rises above the setting, the EP6 terminates the crank cycle. One second delay avoids false termination. The code [Inh.] inhibits the crank termination
- [P.25] **Low Oil Pressure Alarm By-Pass [ 6"]**  
Range: 0-99 secs. By-Pass Delay to ignore the Oil Pressure (input #3) during the engine starting cycle. This input requires normally closed contact
- [P.26] **Automatic Periodic Test Cycle [inh.]**  
Range: [inh.], 1-99 days  
This is the interval time between the automatic periodic tests of the engine. The code [inh.] disables the Automatic Periodic Test (see section 19.0)
- [P.27] **Automatic Engine Test Duration [ 5']**  
Range: 1-99 minutes.  
This is the duration of the automatic engine test.
- [P.28] **Generator warm-up timing [ 20"]**  
Range [inh.] 1-59 secs or 1-15 mins ([inh.]=No warm-up)  
Active only when [P17]= [inh.] and the ALARM output is used to drive the contactor
- [P.29] **Generator cooling timing [ 30"]**  
Range [inh.] 1-59 secs or 1-15 mins ([inh.]=No cooling)  
Active only when [P17]= [inh.] and the ALARM output is used to drive the GEN-SET contactor



**7.0 REMOTE START**

The EP6 features REMOTE START only in AUTO operating mode.

To operate the REMOTE START, follow the instructions.

- A) - Turn the KEY-SWITCH to the ON position; the Display and LEDs illuminate for 1 sec.
- B) - Wait until the end of the LEDs test.
- C) - Push the AUTO pushbutton as soon as possible (otherwise, after 20 seconds the EP6 enters the STARTING FAILURE); the [AUTO] yellow LED will illuminate as described in the next section

**7.1 - REMOTE START SWITCH:**

If the REMOTE START input is activated, the [AUTO] yellow LED illuminates continuously and the display will indicate the count down of the internal **start delay** timer by means of the message [MM.SS] (Minutes and seconds). The engine will start after the programmed **start delay** time. If the REMOTE START is deactivated, the EP6 drives the **stop delay time**. The display will indicate the count down by means of the message [MM.SS] (Minutes and seconds), and the [AUTO] yellow LED will flash. The engine will stop after the programmed **stop delay** time.

**Note start delay time:** see section 6.0 parameter [P.0]

**Note stop delay time:** see section 6.0 parameter [P.1]

**8.0 SAFETY**



**NOTE**

High voltage is present inside the EP6. To avoid electric-shock hazard, operating personnel must not remove the protective cover. Do not disconnect the grounding connection. Any interruption of the grounding connection can create an electric shock hazard. Before making external connections, always ground the PANEL first by connecting the control panel to ground.

**9.0 Automatic periodic TEST**

The EP6 does not use a clock to count the programmed days ([P.26] setting, section 6.0). The maximum error and drift of the counter is +/-0,5%. The user may experiment with shifting the periodic tests. To avoid error accumulation, and in case your unit is programmed to allow Automatic Periodic

Test, we recommend the following procedures.

- disconnect the power supply of the EP6 (*consult your genset supplier*)
- wait for the desired start time (external clock reference)
- apply the power supply to the EP6 (*consult your genset supplier*)
- select the 'AUTO' operating mode

The EP6 will start the engine after the programmed number of days and the engine will run for the programmed time. To determine how the Automatic Periodic Test is programmed enter the Reading Mode (section 6.0 parameter [P.26] and [P.27]).

**IMPORTANT NOTES**

If the supply (battery voltage) is removed, the EP6 loses the counts and timings. If the supply restores, the EP6 starts to count the A.P.T. according to the programmed parameters [P.26] and [P.27]. It is important to synchronize the power on sequence with the desired Automatic Periodic Test.

**10.0 FRONT PANEL**

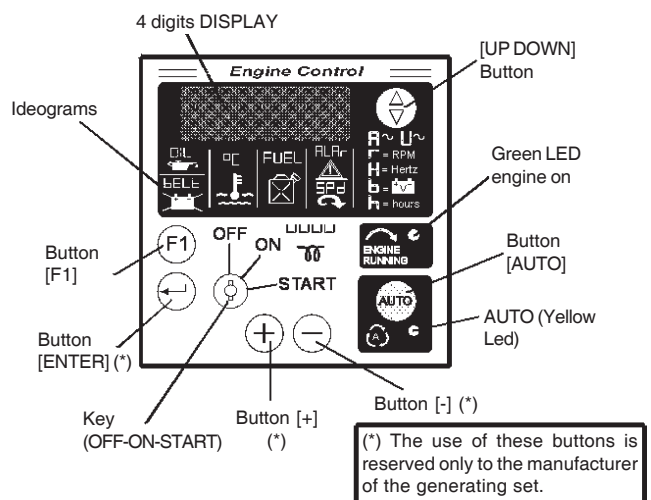

**11.0 DIMENSIONS**

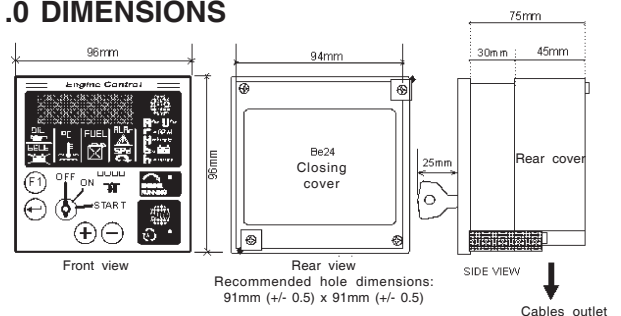

<b>Problem</b>	<b>Possible cause</b>	<b>Solution</b>
<b>ENGINE</b>		
The motor does not start up	1) Start-up switch (I6) (where it is assembled) in incorrect position 2) Emergency button (L5) pressed 3) Preheating (where it is assembled)  4) Engine control unit or starting key faulty. 5) Battery low  6) Battery cable terminals loose or corroded 7) Start-up motor defective 8) No fuel or air in feed circuit 9) Malfunction on feed circuit: defective pump, injector blocked, etc. 10) Air filter or fuel filter clogged 11) Air in the gasoil filter. 12) Motor stopping device defective 13) Malfunction on electrical power circuit on generator control panel	1) Check position  2) Unblock 3) Lacking or insufficient preheating phase for sparkplugs. Malfunction in circuit: repair. 4) Replace  5) Recharge or replace. Check the battery charge circuit on motor and automatic panel. 6) Tighten and clean. Replace if corroded. 7) Repair or replace. 8) Refill tank, un-aerate the circuit. 9) Ask for intervention of Service Department. 10) Clean or replace 11) Take the air out filling the filter with gasoil. 12) Replace. 13) Check and repair.
The motor does not accelerate. Inconstant speed.	1) Air filter or fuel filter clogged. 2) Malfunction on feed circuit: defective pump, injector blocked, etc. 3) Oil level too high. 4) Motor speed regulator defective.	1) Clean or replace. 2) Ask for intervention of Service Department. 3) Eliminate excess oil. 4) Ask for intervention of Service Department
Black smoke	1) Air filter clogged. 2) Overload.  3) Injectors defective. Injection pump requires calibration.	1) Clean or replace 2) Check the load connected and diminish. 3) Ask for intervention of Service Department.
White smoke	1) Oil level too high. 2) Motor cold or in prolonged operation with little or no load. 3) Segments and/or cylinders worn out.	1) Eliminate excess oil. 2) Insert load only with motor sufficiently hot 3) Ask for intervention of Service Department.
Too little power provided by motor.	1) Air filter clogged. 2) Insufficient fuel distribution, impurities or water in feed circuit. 3) Injectors dirty or defective.	1) Clean or replace. 2) Check the feed circuit, clean and refill once again. 3) Ask for intervention of Service Department.
Low oil pressure	1) Oil level insufficient 2) Air filter clogged. 3) Oil pump defective.  4) Alarm malfunction.	1) Reset level. Check for leaks. 2) Replace filter. 3) Ask for intervention of Service Department. 4) Check the sensor and electrical circuit.
High temperature	1) Overload  2) Insufficient ventilation.  3) Insufficient coolant liquid (Only for water cooled motors)	1) Check the load connected and diminish. 2) Check the cooling vent and relative transmission belts 3) Restore level. Check for leaks or breakage in the entire cooling circuit, pipes, couplings, etc.

<b>Problem</b>	<b>Possible cause</b>	<b>Solution</b>
<b>ENGINE</b>		
	4) Water radiator or oil clogged (where it is assembled) 5) Water circulating pump defective (Only for water cooled motors) 6) Injectors defective. Injection pump requires calibration 7) Alarm malfunction	4) Clean cooling fins on radiator 5) Ask for intervention of Service Department 6) Ask for intervention of Service Department 7) Check the sensor and electrical circuit
<b>GENERATOR</b>		
Absence of output voltage	1) Voltage switch in position 0 2) Voltage switch faulty 3) Protection tripped due to overload 4) Differential protection device tripped. (Differential switch, differential relay) 5) Protection devices defective 6) Alternator not sparked 7) Alternator defective	1) Check position 2) Check connections and working of the switch, repair or replace 3) Check the load connected and diminish 4) Check on the entire installation: cables, connections, utilities connected have no defective sheathing which may cause incorrect currents to ground 5) Replace 6) Carry out external spark test as indicated in alternator manual. Ask for intervention of Service Department 7) Check winding, diodes, etc. on alternator (Refer to alternator manual) Repair or replace. Ask for intervention of Service Department
No-load voltage too low or too high	1) Incorrect motor running speed 2) Voltage regulating device (where it is assembled) defective or requires calibration 3) Alternator defective	1) Regulate speed to its nominal no-load value 2) Adjust regulator device as indicated in alternator manual, or replace 3) Check winding, diodes, etc. on alternator (Refer to alternator manual) Repair or replace Ask for intervention of Service Department
Corrected no-load voltage too low with load	1) Incorrect motor running speed due to overload 2) Load with $\cos \varphi$ less than 0.8 3) Alternator defective	1) Check the load connected and diminish 2) Reduce or rephase load 3) Check winding, diodes, etc. on alternator (Refer to alternator manual) Repair or replace Ask for intervention of Service Department
Unstable tension	1) Contacts malfunctioning 2) Irregular rotation of motor 3) Alternator defective	1) Check electrical connections and tighten 2) Ask for intervention of Service Department 3) Check winding, diodes, etc. on alternator (Refer to alternator manual) Repair or replace Ask for intervention of Service Department



## WARNING



**MOVING  
PARTS  
can injure**

- Have **qualified** personnel do maintenance and troubleshooting work.
  - Stop the engine before doing any work inside the machine. If for any reason the machine must be operated while working inside, **pay attention** moving parts, hot parts (exhaust manifold and muffler, etc.) electrical parts which may be unprotected when the machine is open.
  - Remove guards only when necessary to perform maintenance, and replace them when the maintenance requiring their removal is complete.
  - Use suitable tools and clothes.
  - Do not modify the components if not authorized.
- See pag. M1.1 -



**HOT surface  
can  
hurt you**

### NOTE

By maintenance at care of the utilizer we intend all the operatios concerning the verification of mechanical parts, electrical parts and of the fluids subject to use or consumption during the normal operation of the machine.

For what concerns the fluids we must consider as maintenance even the periodical change and or the refills eventually necessary.

Maintenance operations also include machine cleaning operations when carried out on a periodic basis outside of the normal work cycle.

The repairs **cannot be considered** among the maintenance activities, i.e. the replacement of parts subject to occasional damages and the replacement of electric and mechanic components consumed in normal use, by the Assistance Authorized Center as well as by MOSA.

The replacement of tires (for machines equipped with trolleys) must be considered as repair since it is not delivered as standard equipment any lifting system.

The periodic maintenance should be performed according to the schedule shown in the engine manual. An optional hour counter (M) is available to simplify the determination of the working hours.



## IMPORTANT



In the maintenance operations avoid that polluting substances, liquids, exhausted oils, etc. bring damage to people or things or can cause negative effects to surroundings, health or safety respecting completely the laws and/ or dispositions in force in the place.

## ENGINE and ALTERNATOR

**PLEASE REFER TO THE SPECIFIC MANUALS PROVIDED.**

### VENTILATION

Make certain there are no obstructions (rags, leaves or other) in the air inlet and outlet openings on the machine, alternator and motor.

### ELECTRICAL PANELS

Check condition of cables and connections daily. Clean periodically using a vacuum cleaner, **DO NOT USE COMPRESSED AIR.**

### DECALS AND LABELS

All warning and decals should be checked once a year and **replaced** if missing or unreadable.

### STRENUOUS OPERATING CONDITIONS

Under extreme operating conditions (frequent stops and starts, dusty environment, cold weather, extended periods of no load operation, fuel with over 0.5% sulphur content) do maintenance more frequently.

### BATTERY WITHOUT MAINTENANCE DO NOT OPEN THE BATTERY

The battery is charged automatically from the battery charger circuit supplied with the engine.

Check the state of the battery from the colour of the warning light which is in the upper part.

- Green colour: battery OK
- Black colour: battery to be recharged
- White colour: battery to be replaced



## NOTE

THE ENGINE PROTECTION NOT WORK WHEN THE OIL IS OF LOW QUALITY BECAUSE NOT CHARGED REGULARLY AT INTERVALS AS PRESCRIBED IN THE OWNER'S ENGINE MANUAL.





## ATTENTION

- Maintenance operations on the electricity-generating group prearranged for automatic operation must be carried out with the panel in RESET mode.
- Maintenance operations on the installation's electrical panels must be carried out in complete safety by cutting off all external power sources: ELECTRICAL POWER, GROUP and BATTERY.

For the electricity-generating groups prearranged for automatic operation, in addition to carrying out all periodic maintenance operations foreseen for normal usage, various operations must be carried out that are necessary in relation to the specific type of use. The electricity-generating group in fact must be continuously prepared for operation, even after prolonged periods of inactivity.

### MAINTENANCE GENERATING SET WITH AUTOMATIC BOARD

	EVERY WEEK	EVERY MONTH AND/OR AFTER INTERVENTION ON LOAD	EVERY YEAR
1. TEST or AUTOMATIC TEST cycle to keep the generating set constantly operative	NO-LOAD X	WITH LOAD X	
2. Check all levels: engine oil, fuel level, battery electrolyte,, if necessary top it up.	X	X	
3. Control of electrical connections and cleaning of control panel		X	X

**👉 Carry out motor oil change at least once a year, even if the requested number of hours has not been attained.**

In case the machine should not be used for more than 30 days, make sure that the room in which it is stored presents a suitable shelter from heat sources, weather changes or anything which can cause rust, corrosion or damages to the machine.

 Have **qualified** personnel prepare the machine for storage.

### **GASOLINE ENGINE**

Start the engine: It will run until it stops due to the lack of fuel.

Drain the oil from the engine sump and fill it with new oil (see page M25).

Pour about 10 cc of oil into the spark plug hole and screw the spark plug, after having rotated the crankshaft several times.

Rotate the crankshaft slowly until you feel a certain compression, then leave it.

In case the battery, for the electric start, is assembled, disconnect it.

Clean the covers and all the other parts of the machine carefully.

Protect the machine with a plastic hood and store it in a dry place.

### **DIESEL ENGINE**

For short periods of time it is advisable, about every 10 days, to make the machine work with load for 15-30 minutes, for a correct distribution of the lubricant, to recharge the battery and to prevent any possible blocking of the injection system.

For long periods of inactivity, turn to the after sales service of the engine manufacturer.

Clean the covers and all the other parts of the machine carefully.

Protect the machine with a plastic hood and store it in a dry place.

In case of necessity for first aid and of fire prevention, see page. M2.5.



## **IMPORTANT**



In the storage operations avoid that polluting substances, liquids, exhausted oils, etc. bring damage to people or things or can cause negative effects to surroundings, health or safety respecting completely the laws and/or dispositions in force in the place.





☞ Have **qualified** personnel disassemble the machine and dispose of the parts, including the oil, fuel, etc., in a correct manner when it is to be taken out of service.

As cust off we intend all operations to be made, at utilizer's care, at the end of the use of the machine. This comprises the dismantling of the machine, the subdivision of the several components for a further reutilization or for getting rid of them, the eventual packing and transportation of the eliminated parts up to their delivery to the store, or to the bureau encharged to the cust off or to the storage office, etc.

The several operations concerning the cust off, involve the manipulation of fluids potentially dangerous such as: lubricating oil and battery electrolyte.

The dismantling of metallic parts liable to cause injuries or wounds, must be made wearing heavy gloves and using suitable tools.

The getting rid of the various components of the machine must be made accordingly to rules in force of law a/o local rules.

**Particular attention must be paid when getting rid of:**

**lubricating oils, battery electrolyte, and inflammable liquids such as fuel, cooling liquid.**

The machine user is responsible for the observance of the norms concerning the environment conditions with regard to the elimination of the machine being cust off and of all its components.

In case the machine should be cust off without any previous disassembly it is however compulsory to remove:

- tank fuel
- engine lubricating oil
- cooling liquid from the engine
- battery

**NOTE:** MOSA is involved with custing off the machine **only** for the second hand ones, when not reparable.

This, of course, after authorization.

In case of necessity for first aid and fire prevention, see page M2.5.



## IMPORTANT



In the cust-off operations avoid that polluting substances, liquids, exhausted oils, etc. bring damage to people or things or can cause negative effects to surroundings, health or safety respecting completely the laws and/or dispositions in force in the place.



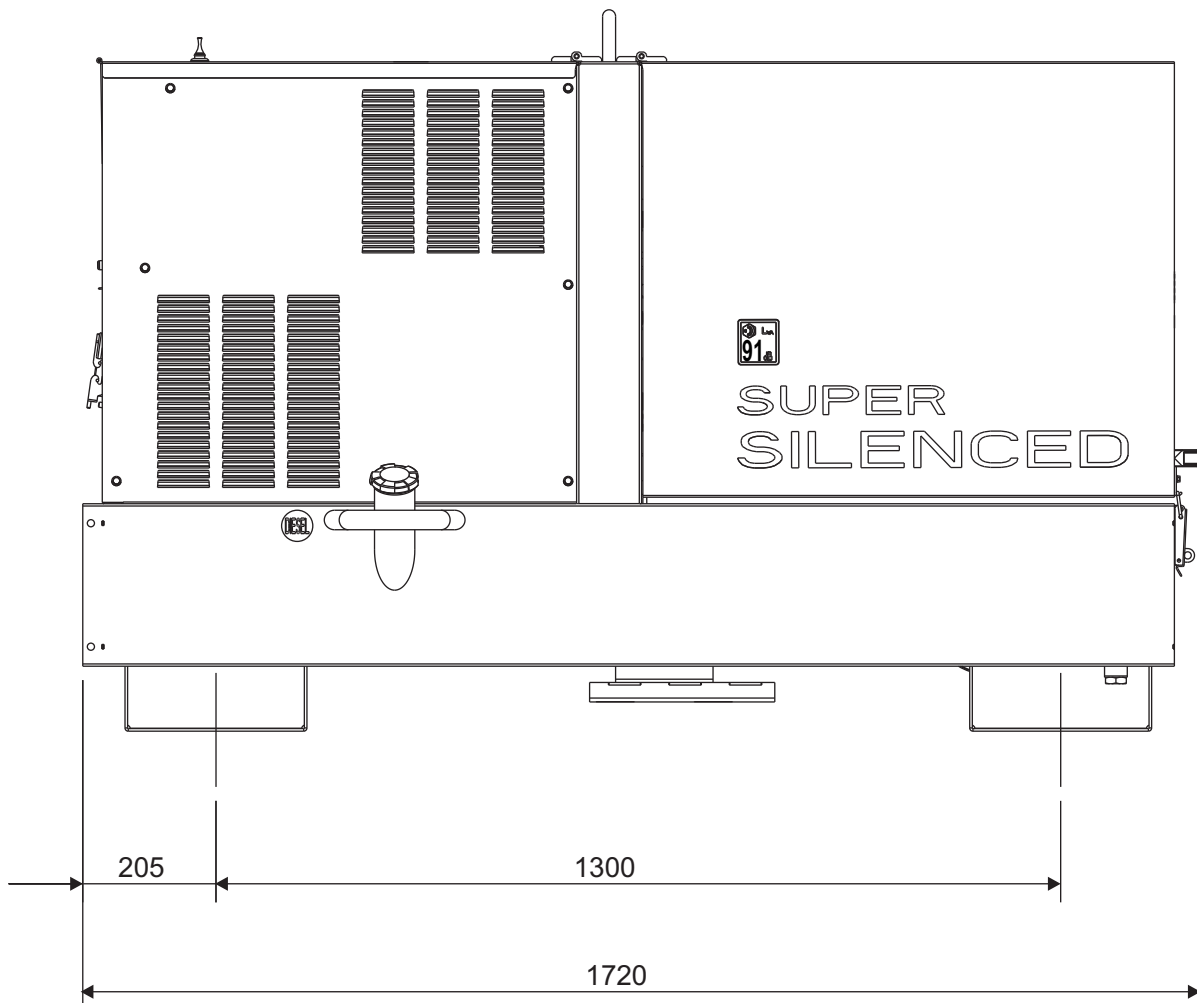
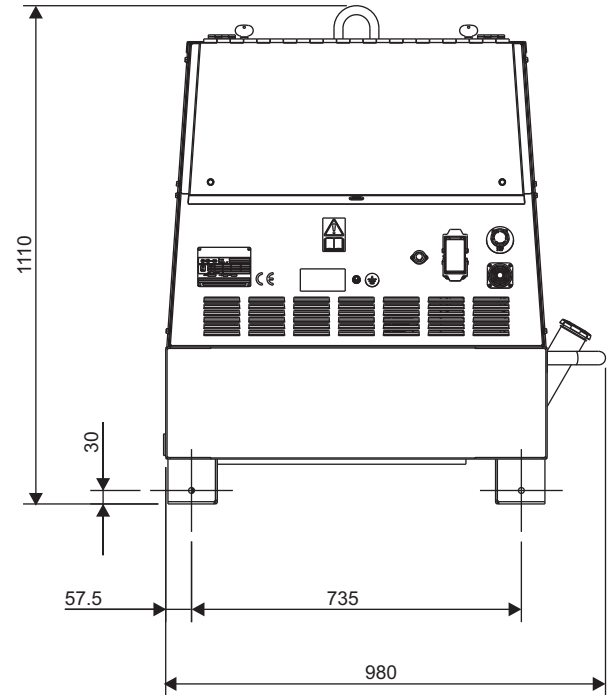
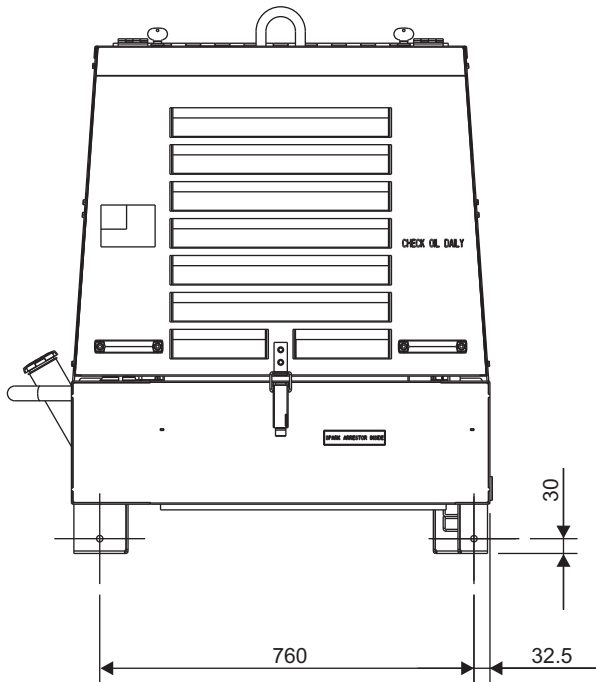

A: Alternator	A3: Insulation monitoring	A6: Commutator/switch
B: Wire connection unit	B3: E.A.S. connector	B6: Key switch, on/off
C: Capacitor	C3: E.A.S. PCB	C6: QEA control unit
D: G.F.I.	D3: Booster socket	D6: Connector, PAC
E: Welding PCB transformer	E3: Open circuit voltage switch	E6: Frequency rpm regulator
F: Fuse	F3: Stop push-button	F6: Arc-Force selector
G: 400V 3-phase socket	G3: Ignition coil	G6: Device starting motor
H: 230V 1phase socket	H3: Spark plug	H6: Fuel electro pump 12V c.c.
I: 110V 1-phase socket	I3: Range switch	I6: Start Local/Remote selector
L: Socket warning light	L3: Oil shut-down button	L6: Choke button
M: Hour-counter	M3: Battery charge diode	M6: Switch CC/CV
N: Voltmeter	N3: Relay	N6: Connector – wire feeder
P: Welding arc regulator	O3: Resistor	O6: 420V/110V 3-phase transformer
Q: 230V 3-phase socket	P3: Sparkler reactor	P6: Switch IDLE/RUN
R: Welding control PCB	Q3: Output power unit	Q6: Hz/V/A analogic instrument
S: Welding current ammeter	R3: Electric siren	R6: EMC filter
T: Welding current regulator	S3: E.P.4 engine protection	S6: Wire feeder supply switch
U: Current transformer	T3: Engine control PCB	T6: Wire feeder socket
V: Welding voltage voltmeter	U3: R.P.M. electronic regulator	U6: DSP chopper PCB
Z: Welding sockets	V3: PTO HI control PCB	V6: Power chopper supply PCB
X: Shunt	Z3: PTO HI 20 l/min push-button	Z6: Switch and leds PCB
W: D.C. inductor	W3: PTO HI 30 l/min push-button	W6: Hall sensor
Y: Welding diode bridge	X3: PTO HI reset push-button	X6: Water heater indicator
	Y3: PTO HI 20 l/min indicator	Y6: Battery charge indicator
A1: Arc striking resistor	A4: PTO HI 30 l/min indicator	A7: Transfer pump selector AUT-0-MAN
B1: Arc striking circuit	B4: PTO HI reset indicator	B7: Fuel transfer pump
C1: 110V D.C./48V D.C. diode bridge	C4: PTO HI 20 l/min solenoid valve	C7: „GECO“ generating set test
D1: E.P.1 engine protection	D4: PTO HI 30 l/min solenoid valve	D7: Flooting with level switches
E1: Engine stop solenoid	E4: Hydraulic oil pressure switch	E7: Voltmeter regulator
F1: Acceleration solenoid	F4: Hydraulic oil level gauge	F7: WELD/AUX switch
G1: Fuel level transmitter	G4: Preheating glow plugs	G7: Reactor, 3-phase
H1: Oil or water thermostat	H4: Preheating gearbox	H7: Switch disconnector
I1: 48V D.C. socket	I4: Preheating indicator	I7: Solenoid stop timer
L1: Oil pressure switch	L4: R.C. filter	L7: "VODIA" connector
M1: Fuel warning light	M4: Heater with thermostat	M7: "F" EDC4 connector
N1: Battery charge warning light	N4: Choke solenoid	N7: OFF-ON-DIAGN. selector
O1: Oil pressure warning light	O4: Step relay	O7: DIAGNOSTIC push-button
P1: Fuse	P4: Circuit breaker	P7: DIAGNOSTIC indicator
Q1: Starter key	Q4: Battery charge sockets	Q7: Welding selector mode
R1: Starter motor	R4: Sensor, cooling liquid temperature	R7: R.C. net
S1: Battery	S4: Sensor, air filter clogging	S7: 230V 1-phase plug
T1: Battery charge alternator	T4: Warning light, air filter clogging	T7: V/Hz analogic instrument
U1: Battery charge voltage regulator	U4: Polarity inverter remote control	U7: Engine protection EP6
V1: Solenoid valve control PCBT	V4: Polarity inverter switch	V7: G.F.I. relay supply switch
Z1: Solenoid valve	Z4: Transformer 230/48V	Z7: Radio remote control receiver
W1: Remote control switch	W4: Diode bridge, polarity change	W7: Radio remote control transmitter
X1: Remote control and/or wire feeder socket	X4: Base current diode bridge	X7: Isometer test push-button
Y1: Remote control plug	Y4: PCB control unit, polarity inverter	Y7: Remote start socket
A2: Remote control welding regulator	A5: Base current switch	A8: Transfer fuel pump control
B2: E.P.2 engine protection	B5: Auxiliary push-button ON/OFF	B8: Ammeter selector switch
C2: Fuel level gauge	C5: Accelerator electronic control	C8: 400V/230V/115V commutator
D2: Ammeter	D5: Actuator	D8: 50/60 Hz switch
E2: Frequency meter	E5: Pick-up	E8: Cold start advance with temp. switch
F2: Battery charge transformer	F5: Warning light, high temperature	F8: START/STOP switch
G2: Battery charge PCB	G5: Commutator auxiliary power	G8: Polarity inverter two way switch
H2: Voltage selector switch	H5: 24V diode bridge	H8: Engine protection EP7
I2: 48V a.c. socket	I5: Y/s commutator	I8: AUTOIDLE switch
L2: Thermal relay	L5: Emergency stop button	L8: AUTOIDLE PCB
M2: Contactor	M5: Engine protection EP5	M8:
N2: G.F.I. and circuit breaker	N5: Pre-heat push-button	N8:
O2: 42V EEC socket	O5: Accelerator solenoid PCB	O8:
P2: G.F.I. resistor	P5: Oil pressure switch	P8:
Q2: T.E.P. engine protection	Q5: Water temperature switch	Q8:
R2: Solenoid control PCBT	R5: Water heater	R8:
S2: Oil level transmitter	S5: Engine connector 24 poles	S8:
T2: Engine stop push-button T.C.1	T5: Electronic GFI relais	T8:
U2: Engine start push-button T.C.1	U5: Release coil, circuit breaker	U8:
V2: 24V c.a. socket	V5: Oil pressure indicator	V8:
Z2: Thermal magnetic circuit breaker	Z5: Water temperature indicator	Z8:
W2: S.C.R. protection unit	W5: Battery voltmeter	W8:
X2: Remote control socket	X5: Contactor, polarity change	X8:
Y2: Remote control plug	Y5: Commutator/switch, series/parallel	Y8:

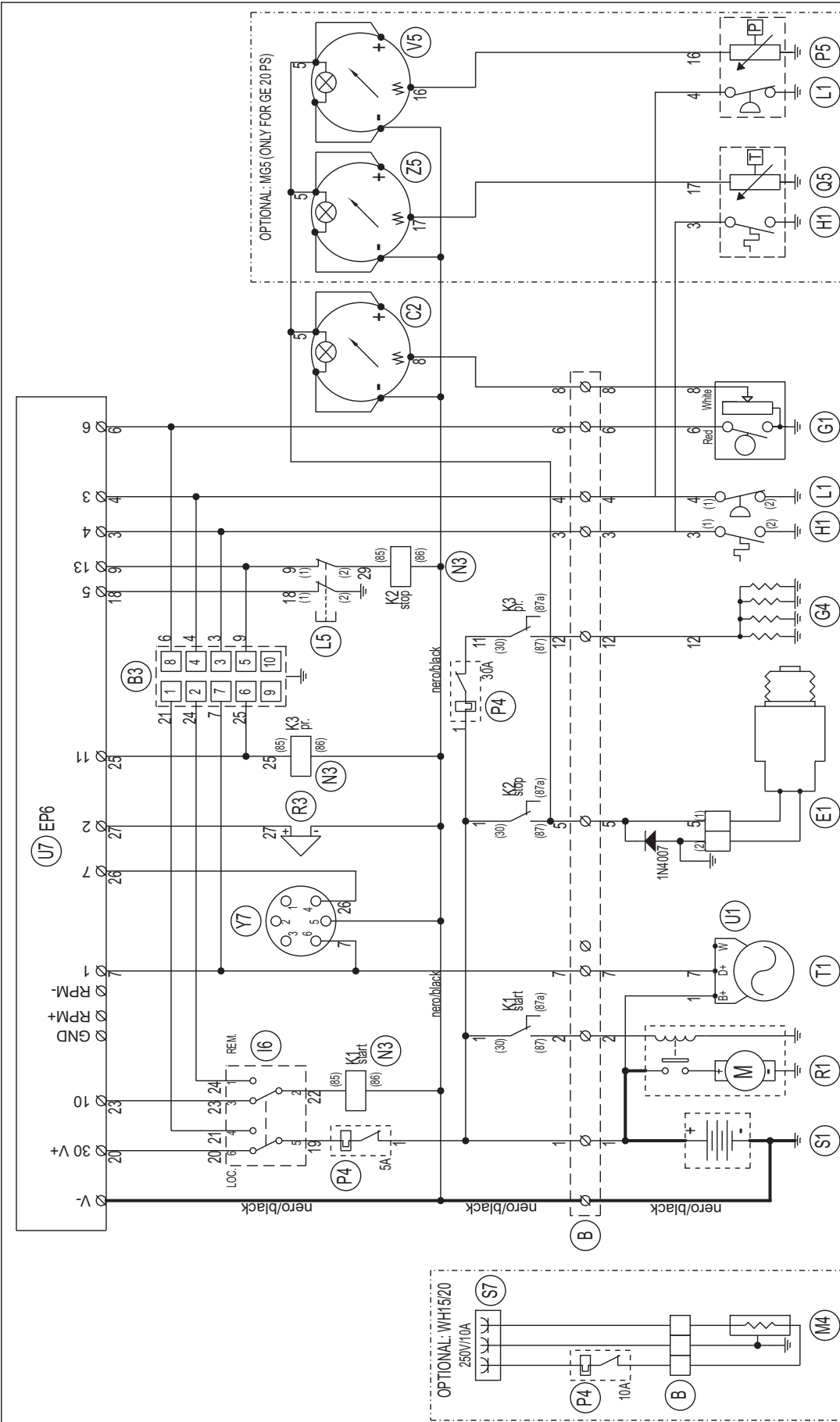

ESP. Exp.	Modifica	08.05.2007	N.L.
	Date		
	Dis. Appl.		
	Project	84210.prg	2
	Page n°		4
	Project		
	Dis. n°		
	Dwg. n°	84210.S.010-A	
	Designator:		
	Designer:		
	Leopance N.		

A Aggiunto accessori MG5 (kit termo/manometro) e WH20 (kit riscald. acqua)

MOSA

Denominazione: Engine Perkins 404C-22G

Macchina: GE 20 PSX

20090-CUSAGO (MI)-ITALY

http://www.mosa.it

La MOSA si riserva a termini di legge la proprietà del presente disegno con divieto di riproduzione o comunicarlo a terzi senza sua autorizzazione.

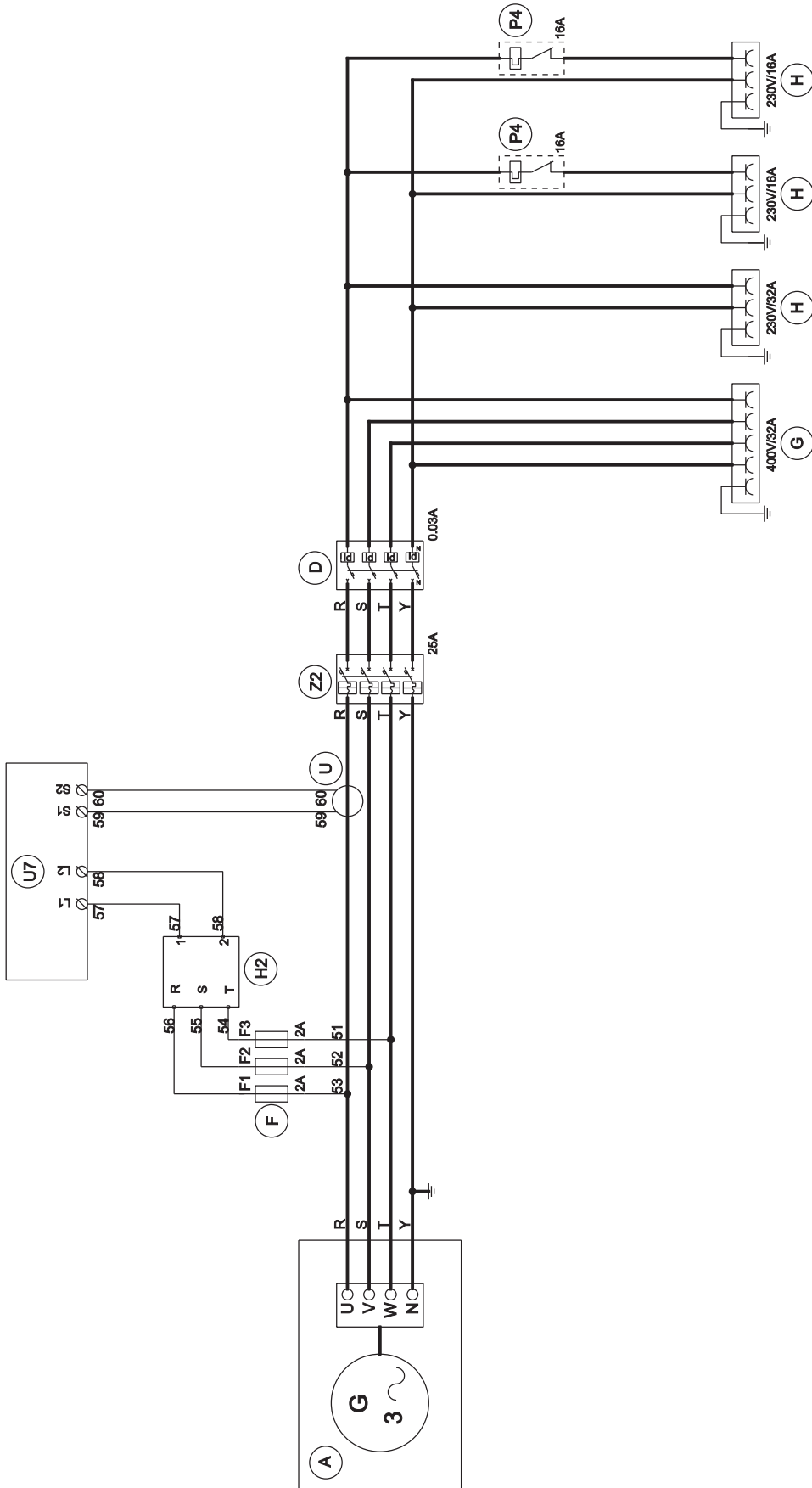

Espr. Edita:	Modifica	Data	Appr.
	Validazione:		
	Denominazione:	84210.prg	Dis. di n°
	Denominazione:	84210.S.020	Page n°
	Disegnato:	27.12.2005	3
	Macchina:	84210.S.020	3
	Machine:		3
	Disegnato:		Approvato:
	Designer:		Approvato:
	Machine:		Approvato:
	Machine:		Approvato:

La MOSA si riserva a termini di legge la proprietà del presente disegno con divieto di riprodurlo o comunicarlo a terzi senza sua autorizzazione

**MOSA guarantees that any request for spare parts will be satisfied.**

To keep the machine in full working order, when replacement of MOSA spare parts is required, always ask for genuine parts only.

👉 The requested data are to be found on the data plate located on the machine structure, quite visible and easy to consult. \*

**When ordering the spare parts, it is recommended to indicate:**

- 1) \* serial number
- 2) \* model of welder and/or generating set
- 3) ◆ n. table
- 4) ◆ n. position
- 5) quantity

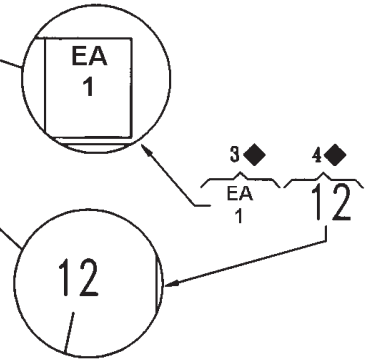
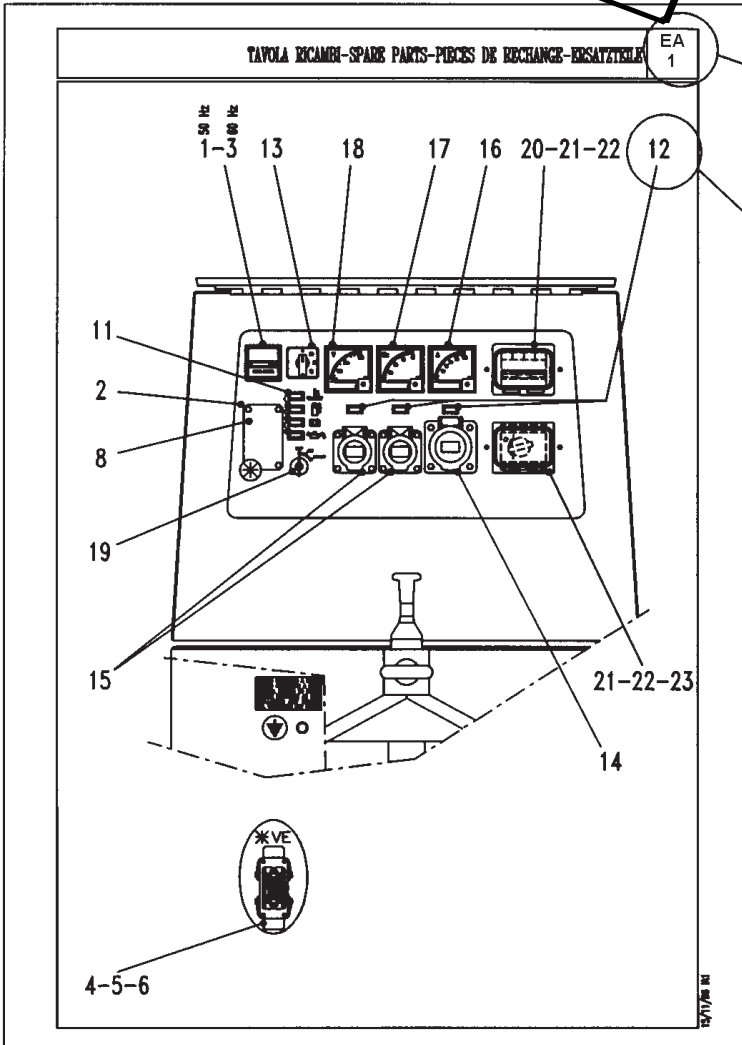
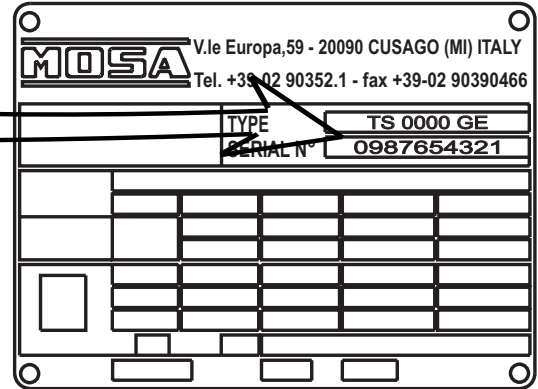

**ABBREVIATIONS AND SYMBOLS:**

- (EV) When ordering, specify the engine type and the auxiliary voltage
- (ER) Engine with recoil starter only
- (ES) Engine with electric starter only
- (VE) E.A.S version only.
- (QM) When ordering, specify the length in meters
- (VS) Special version only
- (SR) By request only

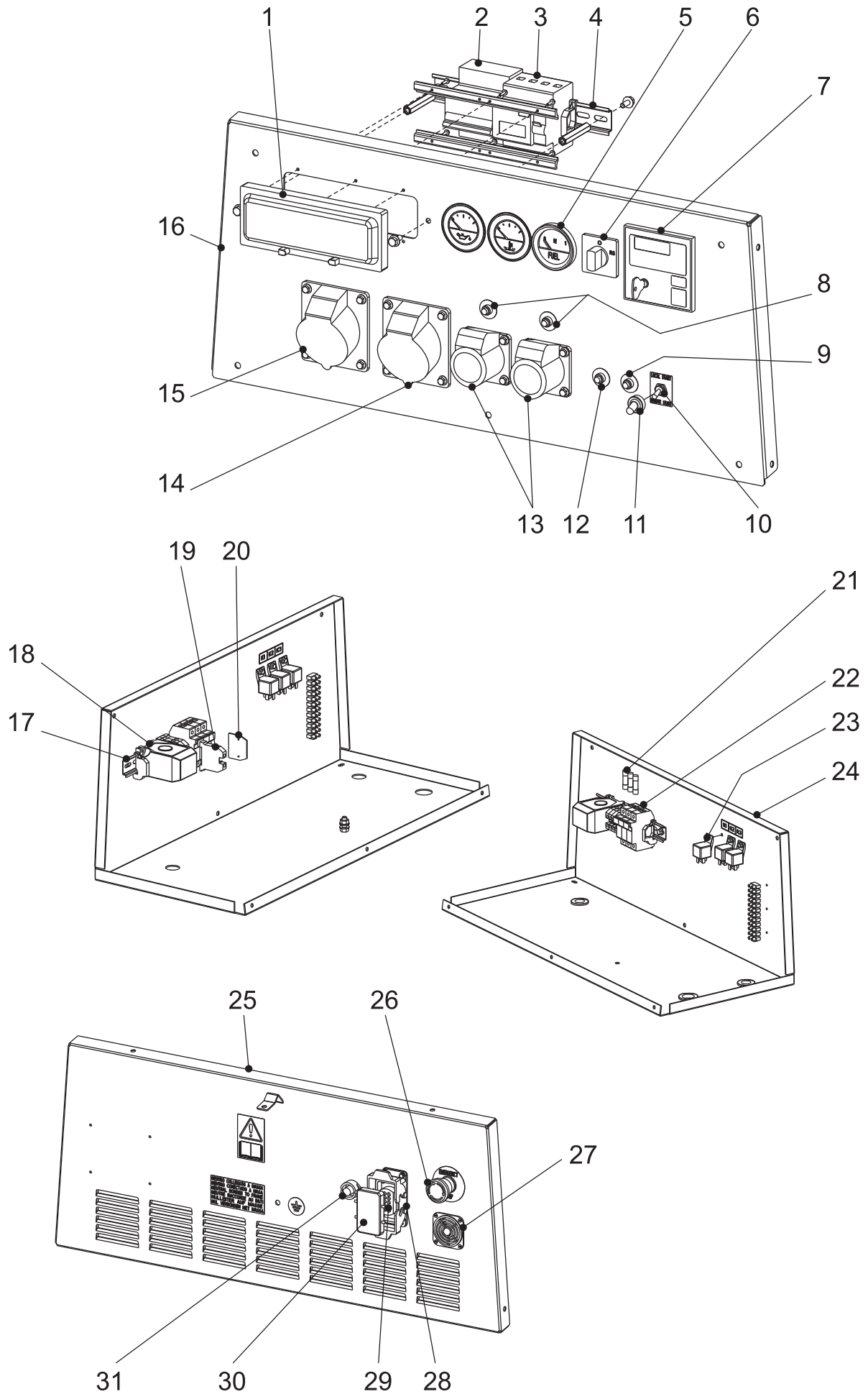



<i>Pos.</i>	<i>Rev. Cod.</i>	<i>Descr.</i>
1	317807130	COPERCHIO PROTEZIONE I.D.
2	105511860	INTERRUTTORE MAGNETOTERMICO
3	105111540	Vedi Cod.219937105
4	1243020	GUIDA PER MORSETTIERA
5	325507210	INDICATORE LIVELLO CARBURANTE
6	305717315	COMMUTATORE
7	JK0029770	UNITA' CONTROLLO MOTERE EP6
8	155307107	DISGIUNTORE TERMICO 15A-250V
9	352007109	PROTEZIONE TERMICA 5A
10	102013290	COMMUTATORE
11	102042740	CAPPUCCIO
12	873407107	DISGIUNTORE TERMICO 30A/250V
13	307017240	PRESA 220V 16A
14	105111520	PRESA CEE 220V MONOF. 2POLI+T
15	105111510	PRESA CEE 380V TRIFASE
16	842107020	PANNELLO FRONTALE (superiore)
17	1243020	GUIDA PER MORSETTIERA
18	125207306	TRASFORMATORE DI CORRENTE
19	1240040	MORSETTO
20	1242060	TERMINALE MORSETTIERA
21	1291190	FUSIBILE
22	107509045	PORTAFUSIBILE
23	306479199	RELE' AVV. ELETTRICO
24	842107010	SCATOLA ELETTRICA
25	842107205	PANNELLO FRONTALE (inferiore)
26	744507219	PULSANTE STOP D'EMERGENZA
27	315507215	AVVISATORE ACUSTICO
28	105191550	CUSTODIA PER PRESA EAS
29	105191560	FRUTTO PRESA CONNETTORE
30	105191570	COPERCHIO PER PRESA EAS
31	84210C021	GR. CAVI MOTORE (FRONTALE)
<i>Pos.</i>	<i>Rev. Cod.</i>	<i>Descr.</i>
1	317807130	COVER PROTECTION
2	105511860	CIRCUIT BREAKER
3	105111540	See part no. 219937105
4	1243020	TERMINAL GUIDE
5	325507210	FUEL LEVEL GAUGE
6	305717315	COMMUTATOR
7	JK0029770	UNIT ENGINE CONTROL EP6
8	155307107	THERMAL SWITCH 15A-250V
9	352007109	THERMOPROTECTION
10	102013290	COMMUTATOR
11	102042740	CAP
12	873407107	CIRCUIT BREAKER 30A/250V
13	307017240	EEC SOCKET 16A, 220V 2P+T
14	105111520	EEC SOCKET SINGLE-PH.220V 2P+
15	105111510	EEC SOCKET THREE-PHASE 380V
16	842107020	FRONT PANEL
17	1243020	TERMINAL GUIDE
18	125207306	CURRENT TRANSFORMER
19	1240040	CLAMP
20	1242060	TERMINAL BLOCK
21	1291190	FUSE
22	107509045	HOLDER, FUSE
23	306479199	RELAY, ELECTRIC START
24	842107010	ELECTRIC BOX
25	842107205	FRONT PANEL
26	744507219	EMERGENCY PUSH BUTTON STOP
27	315507215	ACOUSTIC ALARM SYSTEM
28	105191550	BOX, EAS SOCKET
29	105191560	SOCKET, EAS
30	105191570	BLIND PLATE, EAS SOCKET
31	84210C021	ENGINE CABLES GR.

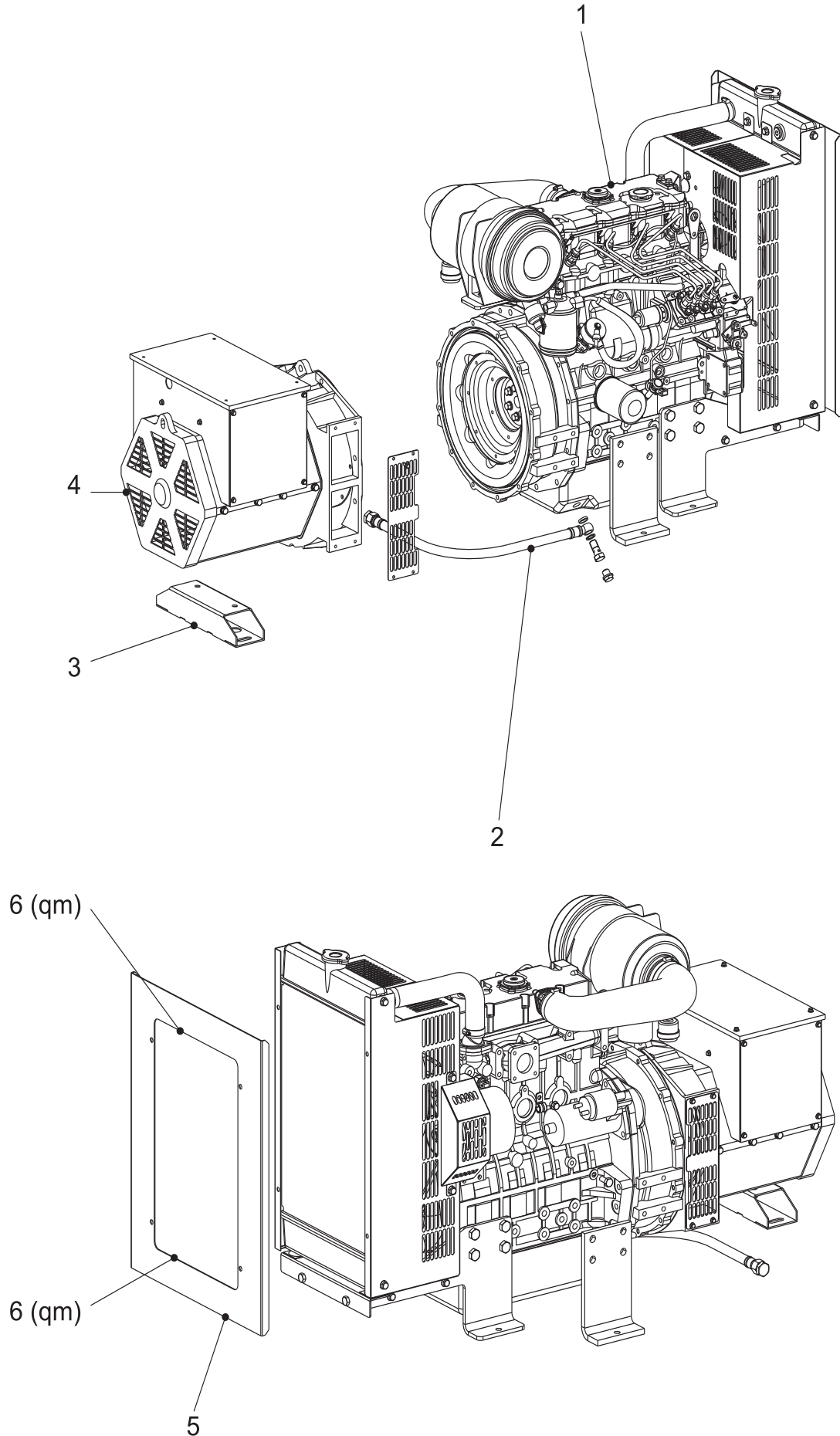

<b>Pos.</b>	<b>Rev. Cod.</b>	<b>Descr.</b>
1	764402200	MOTORE PERKINS 404C-22G <50Hz>(HP35107U)
2	841562212	TUBO SCARICO OLIO
3	742713101	TRAVERSA FISSAGGIO ALTERNATORE
4	842103100	ALT. STAMFORD BC184E 22,5KVA400/230V SAE 4-7
5	764408066	CORNICE RADIATORE
6	105112270	GUARNIZIONE (L=MT.1)
<b>Pos.</b>	<b>Rev. Cod.</b>	<b>Descr.</b>
1	764402200	PERKINS ENGINE
2	841562212	EXHAUST OIL PIPE
3	742713101	ALTERNATOR FIXING BRACKET
4	842103100	STAMFORD ALTERNATOR
5	764408066	GASKET
6	105112270	STRIP, SEALING (L=MT.1)

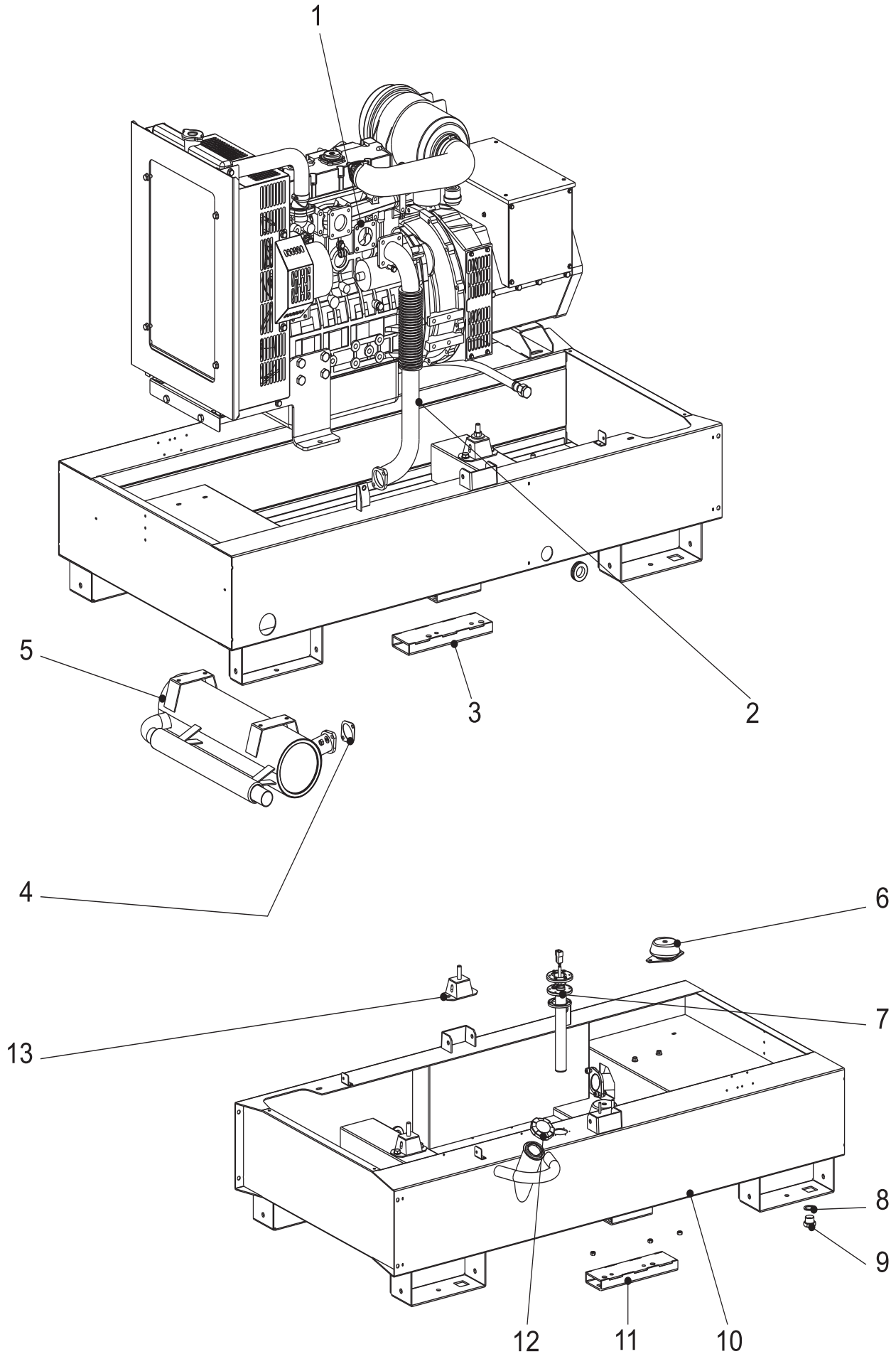

<i>Pos.</i>	<i>Rev. Cod.</i>	<i>Descr.</i>
1	841562071	GUARN.SCARICO MOTORE 403C-15G
2	764402070	TUBO DI SCARICO
3	342201363	SUPPORTO (SX) PER ASSALE
4	305232071	GUARNIZIONE PER FLANGIA
5	764402050	SILENZIATORE SCARICO
6	317801035	ANTIVIBRANTE D.70x45 F-M12
7	308102023	GUARNIZIONE
9	308101262	TAPPO SCARICO SERBATOIO
10	764401050	BASAMENTO
11	342201360	SUPPORTO (DX) PER ASSALE
12	342202026	TAPPO SERBATOIO
13	105612070	ANTIVIBRANTE (40x50)

<i>Pos.</i>	<i>Rev. Cod.</i>	<i>Descr.</i>
1	841562071	GASKET
2	764402070	EXHAUST PIPE
3	342201363	AXLE LEFT SUPPORT
4	305232071	GASKET X FAN
5	764402050	EXHAUST MUFFLER
6	317801035	VIBRATION DAMPER
7	308102023	GASKET
9	308101262	FUEL TANK CAP
10	764401050	BASE
11	342201360	AXLE RIGHT SUPPORT
12	342202026	CAP, FUEL TANK
13	105612070	VIBRATION DAMPER

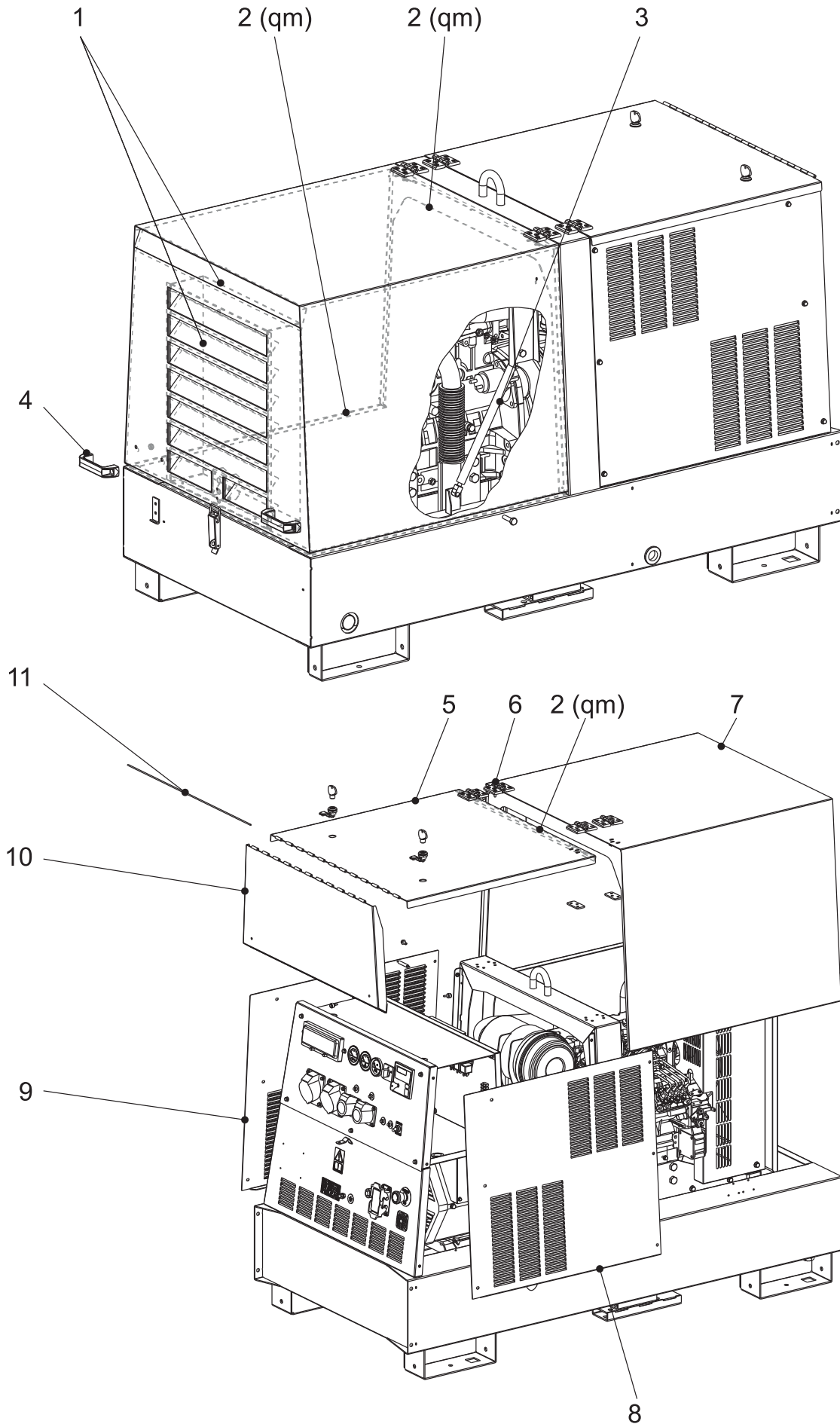



<i>Pos.</i>	<i>Rev. Cod.</i>	<i>Descr.</i>
1	102302280	GUARNIZIONE (L=MT.1)
2	105112270	GUARNIZIONE (L=MT.1)
3	305718115	PISTONE SOSTEGNO
4	343339601	MANIGLIA
5	841508021	COPERCHIO CARENATURA ANTERIORE
6	744508140	CERNIERA PER FIANCATA
7	764408035	CARENATURA POSTERIORE
8	764408010	FIANCATA (dx) CARENATURA ANT.
9	764408015	FIANCATA (sx) CARENATURA ANT.
10	343338100	COPERCHIO FRONTALE
11	343338270	PERNO PER CERNIERA
<i>Pos.</i>	<i>Rev. Cod.</i>	<i>Descr.</i>
1	102302280	GASKET (L=MT.1)
2	105112270	STRIP, SEALING (L=MT.1)
3	305718115	SUPPORT, REAR COVER
4	343339601	KNOB
5	841508021	FRONT HOUSING COVER
6	744508140	LATCH
7	764408035	REAR COVER
8	764408010	FRONT HAUSING RIGHT SIDE
9	764408015	FRONT HAUSING LEFT SIDE
10	343338100	FRONT COVER
11	343338270	HINGE PIN

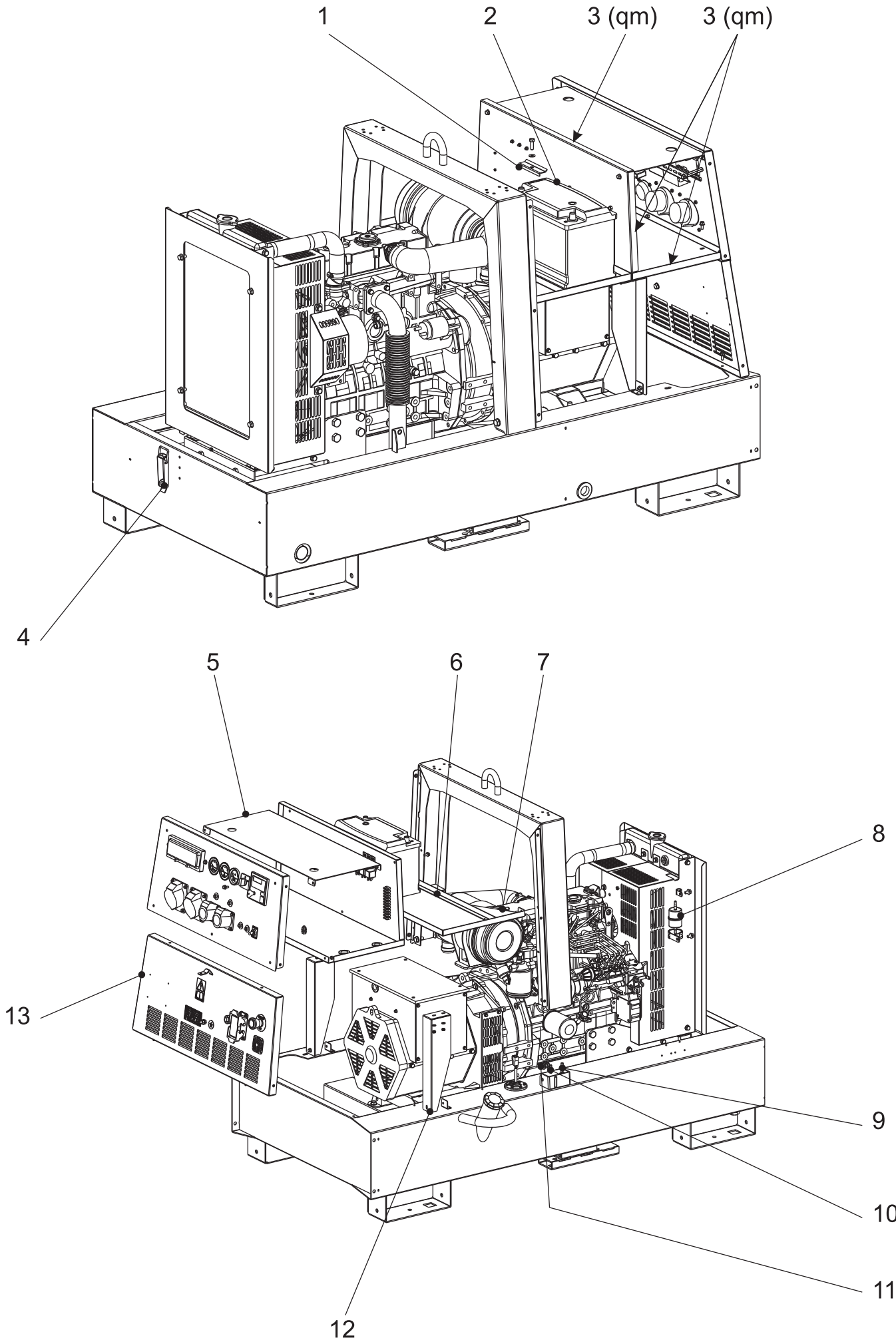

<i>Pos.</i>	<i>Rev. Cod.</i>	<i>Descr.</i>
1	400409154	STAFFA FISSAGGIO BATTERIA
2	764409150	BATTERIA 12V 100Ah(SENZA MANU)
3	105112270	GUARNIZIONE (L=MT.1)
4	107300180	CHIUSURA COMPL.A LEVA
5	764407015	COPERCHIO SCATOLA ELETTRICA
6	764408290	PARATIA SUPERIORE ALTERNATORE
7	764401100	ROLL-BAR
8	256602228	FILTRO GASOLIO
9	308102207	TUBO GOMMA (L=MT.1)
10	107301890	TUBO SFIATO (L=MT.1)
11	307402208	TUBO IN GOMMA (L=MT.1)
12	764408239	TRAVERSINO SUPP. PARATIA ALT.
<i>Pos.</i>	<i>Rev. Cod.</i>	<i>Descr.</i>
1	400409154	BATTERY BRACKET
2	764409150	ELECTRIC BOX COVER
3	105112270	STRIP, SEALING (L=MT.1)
4	107300180	LATCH
5	764407015	ELECTRICAL BOX COVER
6	764408290	ALTERNATOR TOP COVER
7	764401100	ROLL-BAR
8	256602228	FUEL FILTER
9	308102207	PIPE
10	107301890	PIPE, BREATHER (L=MT.1)
11	307402208	RUBBER PIPE
12	764408239	SUPPORT ALTERNATOR BRACKET

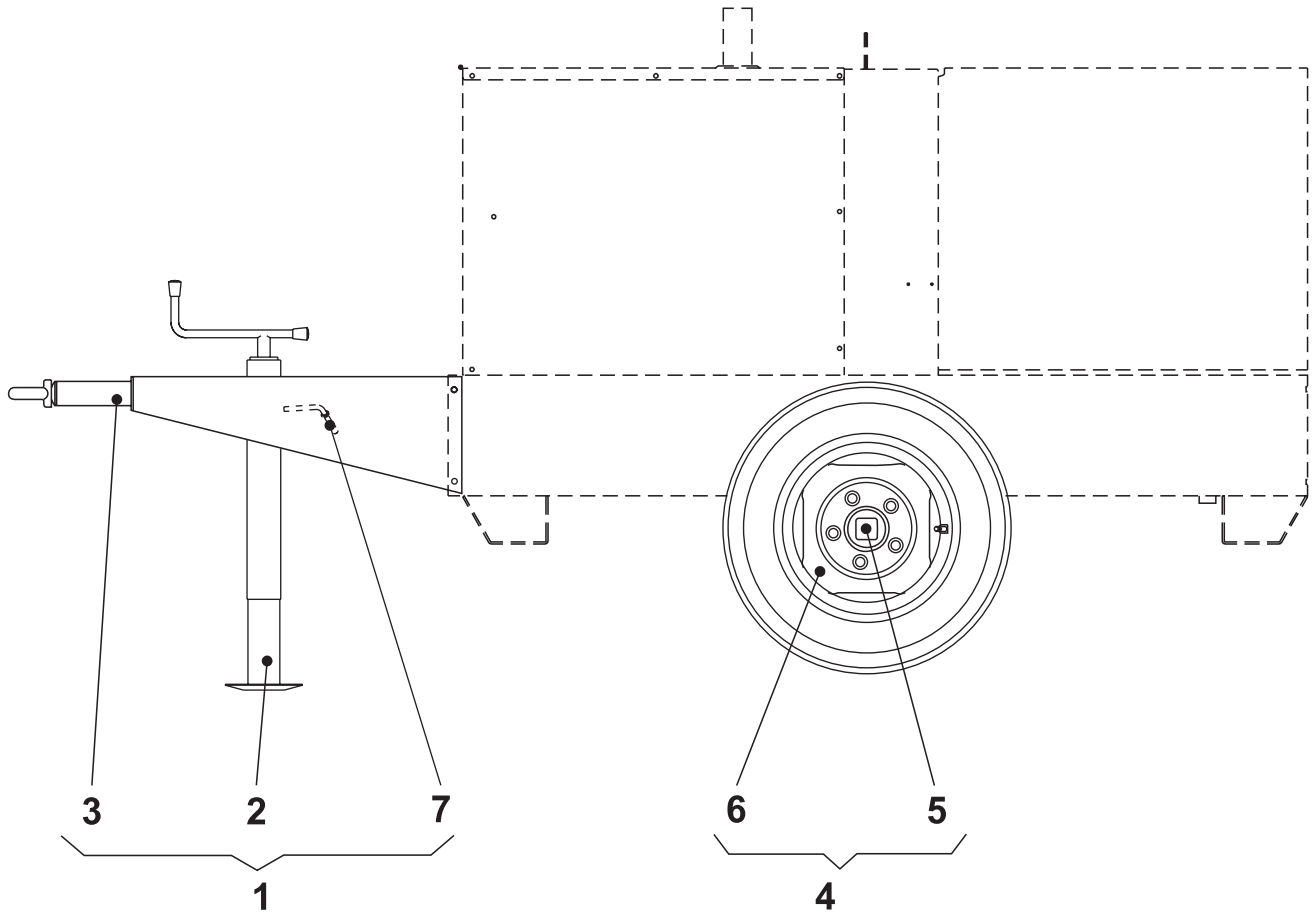

Pos.	Rev.	Cod.	Descr.	Descr.	Note
1		0000225100141	GR.TIMONE,PIEDE x TRAINO LENTO	<i>KIT SITE TOW</i>	Da/from REV.1-02/07 - Del.09 del.26/01/07
1	A	0000305200141	GR.TIMONE,PIEDE xTRAINO LENTO	<i>KIT SITE TOW</i>	Fino a/up to REV. 0-12/02 - Del.09 del.26/01/07
2		342231051	PIEDE DI STAZIONAMENTO	<i>PARKING STAND</i>	Da/from REV.1-02/07 - Del.09 del.26/01/07
2		102351750	PIEDE DI STAZIONAMENTO	<i>PARKING STAND</i>	Fino a/up to REV. 0-12/02 - Del.09 del.26/01/07
3		305751150	TIMONE	<i>TOW BAR</i>	Da/from REV.1-02/07 - Del.09 del.26/01/07
3		305201150	TIMONE	<i>TOW BAR</i>	Fino a/up to REV. 0-12/02 - Del.09 del.26/01/07
4	A	0000305600142	GR.ASSALE,RUOTE x TRAINO LENTO	<i>KIT SITE TOW</i>	era 305600142 10/12/02
5		305751160	ASSALE	<i>AXLE</i>	
6		105612030	RUOTA	<i>WHEEL</i>	
7		305751062	MANIGLIA BLOCC. PIEDE STAZION.	<i>FIXING HANDLE</i> <i>PARKING STAND</i>	Da/from REV.1-02/07 - Del.09 del.26/01/07

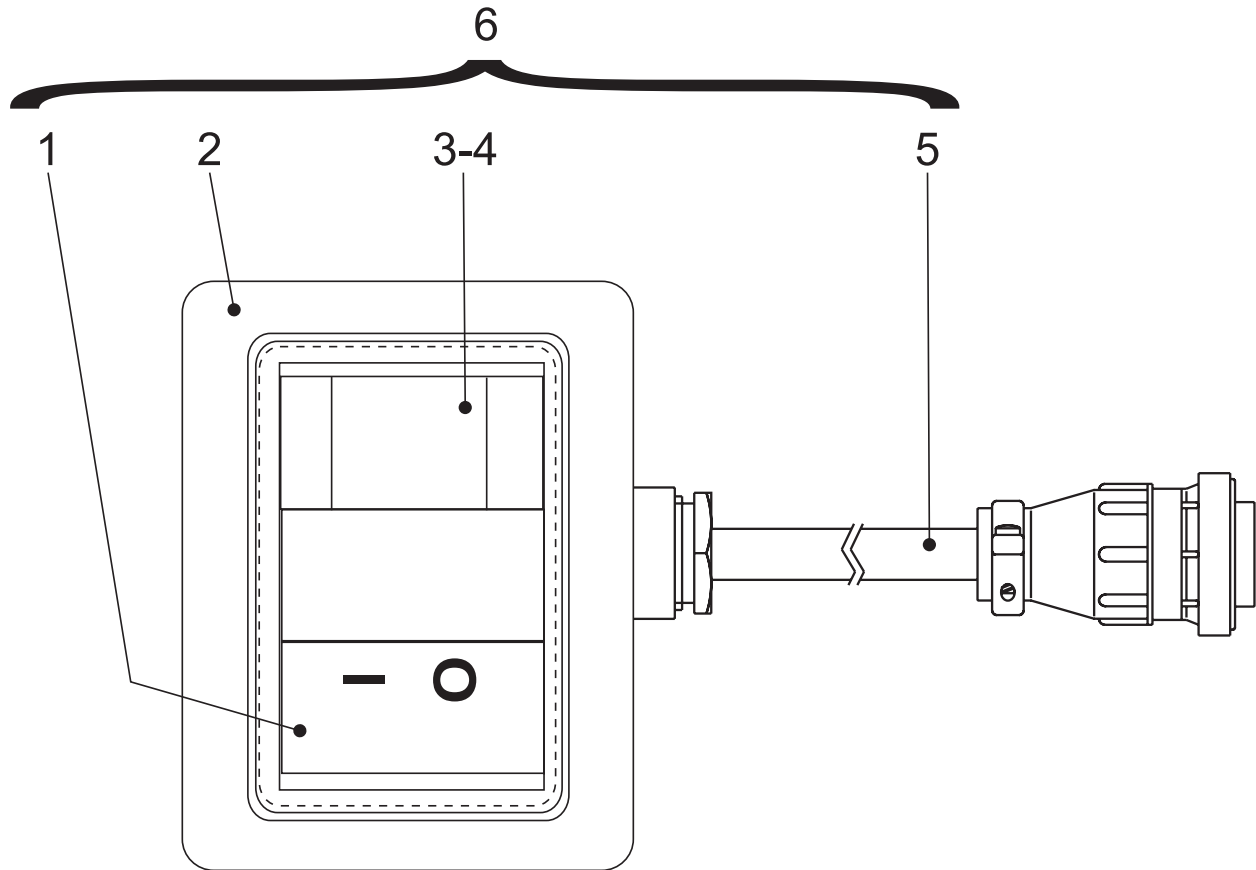

Pos.	Rev.	Cod.	Descr.	Descr.
1		930357219	INTERRUTTORE 2P 16A	INTERRUPTER 2P 16A
2		930359913	SCATOLA COMPLETA	CASE, COMPL.
3		930357227	LAMPADA 24V	WARNING LIGHT 24V
4		930357231	PORTALAMPADA SPIA ROSSA	WARNING LIGHT HOLDER
5		93035C060	GR. CAVI TCM	TCM CABLE KIT
6		930350000	TCM35 COMPLETO	COMPLETE TCM35

