



# GENERATING SET GE 120 BSX



## FEATURES

- Manual digital control panel
- Electronic speed governor
- Four pole circuit breaker
- Automatic voltage regulation "AVR"
- Display of fuel level, water temperature and oil pressure on the control unit
- Low level water radiator sensor
- Central lifting eye
- Bunded base with drain plug
- Oil drain pump
- Meets EC directives



water cooled



diesel



three-phase



electric starter

## POWER RATINGS

* Stand-By three-phase power (LTP)	120 kVA (96 kW) / 400V / 173.2 A
* PRP three-phase power	110 kVA (88kW) / 400V / 159 A
* PRP single-phase power	/
Frequency	50 Hz
Cos φ	0.8

\* Output powers according to ISO 8528-1

## DEFINITION

Valid declared powers up to the followings environmental conditions: temperature 25°C, altitude 100 meters above sea level)

**LTP power: stand-by power:** Maximum available power for use with variable loads for a yearly number of hours limited at 500 h. No overload is admitted.

**PRP power:** continue power with variable loads. Maximum power for use with variable loads for a yearly illimited nubers of hours.

**COP power:** continuous power with constant load. Maximum power for use with constant loads for a yearly unlimited numbers of hours.

## ENGINE 1500 RPM

### 4 STROKE, DIRECT INJECTION, TURBOCHARGED

Model	BAUDOIN 4M11G120/5
* Stand-By net power	106.5 kW (145 hp)
* PRP net power	96.5 kW (131 hp)
* COP net power	/
Cylinders / Displacement	4 / 4500 cm <sup>3</sup> (4.5 lt.)
Bore / Stroke	105 / 130 (mm)
Compression ratio	18 : 1
BMEP (Brake Mean Effective Pressure : LTP - PRP)	/
Speed governor type	Electronic
<b>FUEL CONSUMPTION</b>	
110 % (Stand-by power)	26 lt./h
100 % to PRP	23.2 lt./h
75 % to PRP	17.4 lt./h
50 % to PRP	11.9 lt./h
<b>COOLING SYSTEM</b>	
Total system cap. - only engine	17 lt – 5.3 lt.
Fan air flow	146 m <sup>3</sup> /min.
<b>LUBRIFICATION SYSTEM</b>	
Total oil system capacity	13 l
Oil capacity in sump	9 lt ÷ 11 lt.
Oil consumption at full load	< 0.02 l/h

### EXHAUST SYSTEM

Maximum exhaust gas flow	17 m <sup>3</sup> /min.
Max. exhaust gas temp.	550 °C
Maximum back pressure	6 kPa (0.06 bar)
External diameter exhaust pipe	/
<b>ELECTRICAL SYSTEM</b>	12 Vdc
Starter motor power	4 kW
Battery charging alternator cap.	80 A
Cold start	-10°C
With cold start aid	- 30 °C
<b>AIR FILTER</b>	Dry
Combustion air flow	6 m <sup>3</sup> /min
<b>HEAT REJECTED AT FULL LOAD</b>	
To exhaust system	/
To water and oil	/
Radiated to room	/
To charge cooler	/

\* Output powers according to ISO 3046-1



## ALTERNATOR

SYNCHRONOUS, THREE-PHASE, SELF-EXCITED, SELF-REGULATED, BRUSHLESS	
Continuous power	120 kVA
Stand-by power	132 kVA
Three phase voltage	380 - 440 Vac
Frequency	50 Hz
Cos $\varphi$	0.8
Model A.V.R.	MARK VX.(M00FA122A)
Voltage regulation acc.	$\pm 0,5 \%$
Sustained short circuit current	$\geq 3 I_n$
Transient dip (100% load)	< 20-25 %
Recovery time	< 0.3 sec
Efficiency at 100% load	91 % (400V - Cos $\varphi$ 0.8)
Insulation	Class H
Connection - Terminals	Star - N°12
Electromagnetic compatibility ( R.F.I. suppr.)	EN 55011
Waveform distortion - THD	< 2 %
Telephone interference - THF	< 2 %

REACTANCES (120 kVA - 400V)	
Direct axis synchronuos - Xd	369 %
Direct axis transient - X'd	22 %
Subdirect axis transient - X''d	12.1 %
Quadrature axis synchronuos - Xq	154 %
Quadr. axis subtransient - X''q	13.3 %
Negative sequence - X2	12.7 %
Zero sequence - X0	6 %
TIME CONSTANTS	
Transient - T'd	0.103 sec
Subtransient - T''d	0.01 sec
Open circuit - T'do	1.101 sec
Armature - Ta	0.011 sec
Short-circuit ratio Kcc	0.38
Grado di Protezione IP	IP 23
Cooling air flow	0.2 m <sup>3</sup> /sec.
Coupling   Bearing	Direct SAE 3 -11 ½ - N°1

## GENERAL SPECIFICATIONS

Fuel tank capacity	230 lt.
Running time (75% to PRP)	13.2 h
Starter battery	12 Vdc -100Ah / 720A CCA(EN)
IP protection degree	IP 44

* Measured acoustic power LwA (pressure LpA)	94.3 dB(A) (69.3 dB(A) @ 7m)
* Guaranteed acoustic power LwA (pressure LpA)	96 dB(A) (71 dB(A) @ 7m)
Performance class (ISO 8528)	G3

\* Acoustic power according to European Directive 2000/14/CE

## CONTROL PANEL

- Controller IntiLite AMF25
- Controller supply switch
- Siren
- Emergency stop button
- TCM 35 remote control plug
- Four pole circuit breaker
- PAC (ATS) plug - Automatic control panel only
- Battery charger - Automatic control panel only
- Earth terminal (PE)

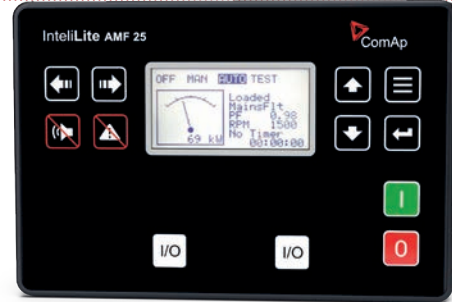

AMF25 CONTROLLER CHARACTERISTICS	
Operating mode	<ul style="list-style-type: none"> <li>• OFF - MAN. - AUTO - TEST</li> </ul>
Display	<ul style="list-style-type: none"> <li>• Graphic back-light LCD display 128x64 pixels</li> </ul>
LEDs	<ul style="list-style-type: none"> <li>• Gen-set voltage OK</li> <li>• Gen-set failure</li> <li>• GCB ON (only for Automatic transfer unit)</li> <li>• Mains voltage OK (only for Automatic transfer unit)</li> <li>• Mains failure (only for Automatic transfer unit)</li> <li>• MCB ON (only for Automatic transfer unit)</li> </ul>
Buttons	<ul style="list-style-type: none"> <li>• START button</li> <li>• STOP button</li> <li>• FAULT RESET button</li> <li>• RESET HORN button</li> <li>• MODE selection button</li> <li>• Pulsante chiusura/apertura GCB button</li> <li>• Pulsante chiusura/apertura MCB button</li> <li>• N° 4 buttons for controller programming</li> </ul>
Generator Measures	<ul style="list-style-type: none"> <li>• Voltage : L1-L2 / L2-L3 / L3-L1 - N-L1/N-L2/N-L3</li> <li>• Current : I1 - I2 - I3</li> <li>• Powers : kVA - kW - kVAR (totali e per fase)</li> <li>• Energy : kVAh - kWh - kVARh</li> <li>• Cos φ (medium and per phase)</li> <li>• Frequency</li> </ul>
Engine Measures	<ul style="list-style-type: none"> <li>• Water temperature</li> <li>• Oil pressure</li> <li>• Fuel level</li> <li>• Rpm meter</li> <li>• Battery voltage</li> <li>• Maintenance</li> <li>• Hours meter</li> <li>• Starts number</li> </ul>
Generator Protections	<ul style="list-style-type: none"> <li>• Overload</li> <li>• Overcurrent</li> <li>• Short circuit</li> <li>• Over-Undervoltage</li> <li>• Over-Underfrequency</li> <li>• Voltage asymmetry</li> <li>• Unbalanced current</li> <li>• Phase sequence</li> </ul>
Engine Protections	<ul style="list-style-type: none"> <li>• Overspeed</li> <li>• High water temperature warning</li> <li>• Low oil pressure warning</li> <li>• Low fuel level warning</li> <li>• Over-Under battery voltage</li> <li>• Battery charge alternator failure</li> <li>• Start failure</li> <li>• Stop failure</li> <li>• Emergency stop</li> <li>• Low water level shutdown (option)</li> </ul>

AMF functions (Automatic control panel only)	<ul style="list-style-type: none"> <li>• Measure mains voltage : L1-L2 / L2-L3 / L3-L1 - N-L1/N-L2/N-L3</li> <li>• Measure mains frequency</li> <li>• Three phase detection</li> <li>• Over-Under mains voltage</li> <li>• Over-Under mains frequency</li> <li>• Voltage asymmetry</li> <li>• Phase sequence</li> <li>• Dual mutual stand-by application</li> </ul>
Features	<ul style="list-style-type: none"> <li>• Historical events</li> <li>• 3 programmable test timers</li> <li>• Panel or PC programming</li> <li>• 3 selectable languages</li> <li>• Direct connection to engines with ECU via Can Bus J1939</li> <li>• External start and stop</li> <li>• Programmable inputs and outputs</li> <li>• Alternative configurations (50 / 60Hz)</li> <li>• IP 65 protection</li> <li>• Operating temperature: -20 ° C - + 70 ° C</li> </ul>
Communication	<ul style="list-style-type: none"> <li>• RTU Modbus (optional board with RS232 &amp; RS485 outputs is needed)</li> <li>• TCP/IP Modbus (optional Ethernet board with RJ45 output is needed)</li> <li>• SNMP Modbus (optional Ethernet board with RJ45 output is needed)</li> <li>• Internet (optional Ethernet board optional is needed)</li> <li>• GSM/GPRS (integrated Modem board optional is needed) for Gen-set remote control via SMS or internet</li> <li>• GPS / 4G modem (optional) (geographical tracking via WebSupervisor</li> </ul>

CONTROL PANEL VERSION WITH OUTPUT SOCKETS	
<b>SOCKETS</b>	1x 125A 400V 3P-N-T IP67
Each socket is protect by own automatic switch.	1x 63A 400V 3P-N-T IP67
Circuit breaker for 125A and 63A sockets.	1x 32A 400V 3P-N-T IP67
GFI and circuit breaker 30mA for 32A and 16A socket.	1x 16A 400V 3P-N-T IP67
	1x 230V 2P-T IP67
	1x 230V 2P-T Schuko IP54



# WEIGHT - DIMENSIONS AND ACCESSORIES

GE 120 BSX



**DRY WEIGHT MACHINE:**  
• 1825kg

Generating set pictured may include optional accessories.



**DIMENSIONS DRAW**

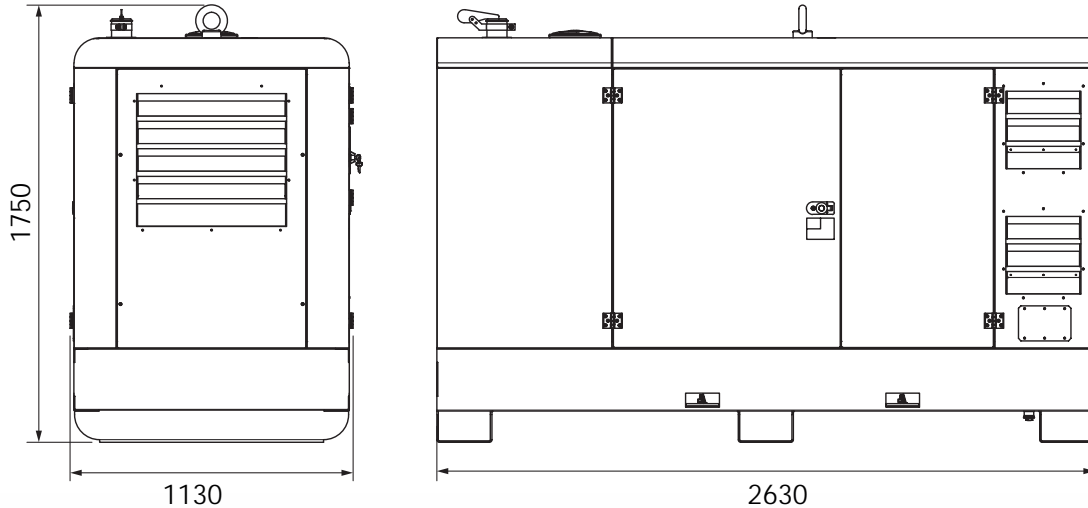

### OPTIONS ON REQUEST

- Automatic transfer switch unit (ATS) PAC 111-M (160A)
- Remote control TCM35
- Earthing kit



### VERSIONS ON REQUEST

- The electrical panel with Sockets CEE
- Manual digital control panel (without sockets)
- Parallel switch board



### FACTORY INSTALLATION OPTIONS

- Electronic leakage relay
- Isometer
- Volt adjustable from control panel
- Tank 350l
- 3-way valve fuel system with quick connection for external fuel tank supply
- Engine water heater WH
- Spark arrestor
- Main battery switch
- Low level water sensor
- Plug-in module with double RS232 and RS485 ports
- GSM modem with antenna
- GPS / 4G modem with antenna
- Internet / Ethernet plug-in module with Web Server
- Reporting card 15 alarms / states (ref. IGL-RA15)
- Input / Output extension module (N ° 16 tot.)

## GENERAL INFORMATION

### COMPLIANCE GENERATING SETS WITH EC DIRECTIVES AND STANDARDS

- 2006/42 / EC (Machines Directive)
- 2014/35 / EU (Low Voltage Directive)
- 2014/30 / EU (EMC Directive)
- 2000/14 / EC (Directive Acoustic Emission for machines for use outdoors)
- ISO 8528 (Reciprocating internal combustion engine driven alternating current generating sets)



ISO 9001:2008 - Cert. 0192

### WARRANTY

All devices are covered by the manufacturer's warranty.

The company reserves the right to change this specification without notice. For further information please contact the sales department.

© MOSA - Viale Europa, 59 - 20090 Cusago (Milano) - Italy - phone +39-0290352.1 - fax + 39-0290390466 E-mail: info@mosa.it Web site: www.mosa.it

