

# GENERATING SET GE 185 FXC

The images are for reference



## FEATURES

- Automatic voltage regulation "AVR"
- Large doors for better and easy maintenance (air, oil, fuel filters replacement)
- Control panel with digital control unit available with automatic or manual version
- Bunded base suitable to contain any liquids leakage from engine avoiding environmental pollution
- Single point lifting eye
- Meets EC directives for noise and safety



water cooled



diesel



three-phase power



electric starter

POWER RATINGS	
* Stand-By three-phase power (LTP)	192 kVA (153.6 kW) / 400V / 277A
* PRP three-phase power	175 kVA (140 kW) / 400V / 252.6A
* PRP single-phase power	140 kVA (112 kW) / 400V / 202A
Frequency	50 Hz
Cos φ	0.8

\* Output powers according to ISO 8528-1

## DEFINITION

Valid declared powers up to the followings environmental conditions: temperature 25°C, altitude 100 meters above sea level)

**LTP power: stand-by power:** Maximum available power for use with variable loads for a yearly number of hours limited at 500 h. No overload is admitted.

**PRP power:** continue power with variable loads. Maximum power for use with variable loads for a yearly illimited nubers of hours.

**COP power:** continuous power with constant load. Maximum power for use with constant loads for a yearly unlimited numbers of hours.

## ENGINE 1500 RPM

4 STROKE, DIRECT INJECTION, TURBOCHARGED	
Model	FPT (IVECO) N67 TM4 (Stage 3A)
* Stand-By net power	165 kW (224 hp)
* PRP net power	150 kW (190 hp)
* COP net power	119 kW (162 hp)
Cylinders / Displacement	6/ 6700 cm <sup>3</sup> (6.7 lit.)
Bore / Stroke	104 / 132 (mm)
Compression ratio	17.5 : 1
BMEP (Brake Mean Effective Pressure : LTP - PRP)	2030 kPa - 1850 kPa
Speed governor type	Mechanic
<b>FUEL CONSUMPTION</b>	
110 % (Stand-by power)	42.2 lit./h
100 % to PRP	36.6 lit./h
75 % to PRP	29.4 lit./h
50 % to PRP	18 lit./h
<b>COOLING SYSTEM</b>	
Total system cap. - only engine	25.5 lit. - 10.5 lit.
Fan air flow	228 m <sup>3</sup> /min.
<b>LUBRIFICATION SYSTEM</b>	
Total oil system capacity	17 lit.
Oil capacity in sump	8 lit. (min) - 12 lit. (max)
Oil consumption at full load	< 0.04 lit./h

\* Output powers according to ISO 3046-1

EXHAUST SYSTEM	
Maximum exhaust gas flow	12.35 kg/mim.
Max. exhaust gas temp.	497 °C
Maximum back pressure	5 kPa (0,05 bar)
External diameter exhaust pipe	/
<b>ELECTRICAL SYSTEM</b>	
Starter motor power	3 kW
Battery charging alternator cap.	90 A
Cold start	- 10 °C
With cold start aid	- 25°C
<b>AIR FILTER</b>	
Combustion air flow	10.5 m <sup>3</sup> /min
<b>HEAT REJECTED AT FULL LOAD</b>	
To exhaust system	598 kcal/kWh
To water and oil	443 kcal/kWh
Radiated to room	107 kcal/kWh
To charge cooler	98 kcal/kWh



## ALTERNATOR

SYNCHRONOUS, THREE-PHASE, SELF-EXCITED, SELF-REGULATED, BRUSHLESS	
Continuous power	185 kVA
Stand-by power	205 kVA
Three phase voltage	380 - 415 Vac
Frequency	50 Hz
Cos $\varphi$	0.8
Model A.V.R.	MARK I (M40FA640A_A)
Voltage regulation acc.	$\pm 0.5\%$
Sustained short circuit current	800A
Transient dip (100% load)	< 20 %
Recovery time	< 0.3 sec
Efficiency at 100% load	93 % (400V - Cos $\varphi$ 0.8)
Insulation	Class H
Connection - Terminals	Star - N°12
Electromagnetic compatibility ( R.F.I. suppr.)	EN 55011
Waveform distortion - THD	< 2 %
Telephone interference - THF	< 2 %

REACTANCES (185 kVA - 400V)	
Direct axis synchronuos - Xd	270 %
Direct axis transient - X'd	24 %
Subdirect axis transient - X''d	12.5 %
Quadrature axis synchronuos - Xq	130 %
Quadr. axis subtransient - X''q	13.9 %
Negative sequence - X2	13.2 %
Zero sequence - X0	2.4 %
TIME CONSTANTS	
Transient - T'd	0.09 sec
Subtransient - T''d	0.011 sec
Open circuit - T'do	0.95 sec
Armature - Ta	0.013 sec
Short-circuit ratio Kcc	0.45
Grado di Protezione IP	IP 23
Cooling air flow	0.42 m <sup>3</sup> /sec.
Coupling I Bearing	Direct SAE 3 - 11 1/2 - N°1

## GENERAL SPECIFICATIONS

Fuel tank capacity	230 lt.
Running time (75% to PRP)	8.4 h
Starter battery	12 Vdc -100Ah / 800A CCA(EN)
IP protection degree	IP 44

* Measured acoustic power LwA (pressure LpA)	95.3 dB(A) (70.3 dB(A) @ 7m)
* Guaranteed acoustic power LwA (pressure LpA)	97 dB(A) (72 dB(A) @ 7m)
Performance class (ISO 8528)	G3

\* Acoustic power according to European Directive 2000/14/CE

## CONTROL PANEL

- Controller IntiLite AMF25
- Controller supply switch
- Siren
- Emergency stop button
- TCM 35 remote control plug
- Four pole circuit breaker
- PAC (ATS) plug - Automatic control panel only
- Battery charger - Automatic control panel only
- Earth terminal (PE)

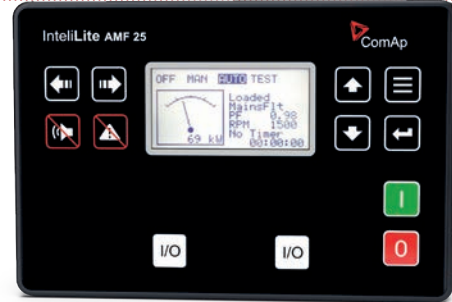

AMF25 CONTROLLER CHARACTERISTICS	
Operating mode	<ul style="list-style-type: none"> <li>• OFF - MAN. - AUTO - TEST</li> </ul>
Display	<ul style="list-style-type: none"> <li>• Graphic back-light LCD display 128x64 pixels</li> </ul>
LEDs	<ul style="list-style-type: none"> <li>• Gen-set voltage OK</li> <li>• Gen-set failure</li> <li>• GCB ON (only for Automatic transfer unit)</li> <li>• Mains voltage OK (only for Automatic transfer unit)</li> <li>• Mains failure (only for Automatic transfer unit)</li> <li>• MCB ON (only for Automatic transfer unit)</li> </ul>
Buttons	<ul style="list-style-type: none"> <li>• START button</li> <li>• STOP button</li> <li>• FAULT RESET button</li> <li>• RESET HORN button</li> <li>• MODE selection button</li> <li>• Pulsante chiusura/apertura GCB button</li> <li>• Pulsante chiusura/apertura MCB button</li> <li>• N° 4 buttons for controller programming</li> </ul>
Generator Measures	<ul style="list-style-type: none"> <li>• Voltage : L1-L2 / L2-L3 / L3-L1 - N-L1/N-L2/N-L3</li> <li>• Current : I1 - I2 - I3</li> <li>• Powers : kVA - kW - kVAR (totali e per fase)</li> <li>• Energy : kVAh - kWh - kVARh</li> <li>• Cos φ (medium and per phase)</li> <li>• Frequency</li> </ul>
Engine Measures	<ul style="list-style-type: none"> <li>• Water temperature</li> <li>• Oil pressure</li> <li>• Fuel level</li> <li>• Rpm meter</li> <li>• Battery voltage</li> <li>• Maintenance</li> <li>• Hours meter</li> <li>• Starts number</li> </ul>
Generator Protections	<ul style="list-style-type: none"> <li>• Overload</li> <li>• Overcurrent</li> <li>• Short circuit</li> <li>• Over-Undervoltage</li> <li>• Over-Underfrequency</li> <li>• Voltage asymmetry</li> <li>• Unbalanced current</li> <li>• Phase sequence</li> </ul>
Engine Protections	<ul style="list-style-type: none"> <li>• Overspeed</li> <li>• High water temperature warning</li> <li>• Low oil pressure warning</li> <li>• Low fuel level warning</li> <li>• Over-Under battery voltage</li> <li>• Battery charge alternator failure</li> <li>• Start failure</li> <li>• Stop failure</li> <li>• Emergency stop</li> <li>• Low water level shutdown (option)</li> </ul>

AMF functions (Automatic control panel only)	<ul style="list-style-type: none"> <li>• Measure mains voltage : L1-L2 / L2-L3 / L3-L1 - N-L1/N-L2/N-L3</li> <li>• Measure mains frequency</li> <li>• Three phase detection</li> <li>• Over-Under mains voltage</li> <li>• Over-Under mains frequency</li> <li>• Voltage asymmetry</li> <li>• Phase sequence</li> <li>• Dual mutual stand-by application</li> </ul>
Features	<ul style="list-style-type: none"> <li>• Historical events</li> <li>• 3 programmable test timers</li> <li>• Panel or PC programming</li> <li>• 3 selectable languages</li> <li>• Direct connection to engines with ECU via Can Bus J1939</li> <li>• External start and stop</li> <li>• Programmable inputs and outputs</li> <li>• Alternative configurations (50 / 60Hz)</li> <li>• IP 65 protection</li> <li>• Operating temperature: -20 ° C - + 70 ° C</li> </ul>
Communication	<ul style="list-style-type: none"> <li>• RTU Modbus (optional board with RS232 &amp; RS485 outputs is needed)</li> <li>• TCP/IP Modbus (optional Ethernet board with RJ45 output is needed)</li> <li>• SNMP Modbus (optional Ethernet board with RJ45 output is needed)</li> <li>• Internet (optional Ethernet board optional is needed)</li> <li>• GSM/GPRS (integrated Modem board optional is needed) for Gen-set remote control via SMS or internet</li> <li>• GPS / 4G modem (optional) (geographical tracking via WebSupervisor</li> </ul>

CONTROL PANEL VERSION WITH OUTPUT SOCKETS	
<b>SOCKETS</b>	1x 125A 400V 3P-N-T IP67
Each socket is protect by own automatic switch.	1x 63A 400V 3P-N-T IP67
Circuit breaker for 125A and 63A sockets.	1x 32A 400V 3P-N-T IP67
GFI and circuit breaker 30mA for 32A and 16A socket.	1x 16A 400V 3P-N-T IP67
	1x 230V 2P-T IP67
	1x 230V 2P-T Schuko IP54



# WEIGHT - DIMENSIONS AND ACCESSORIES

GE 185 FXC



## DRY WEIGHT MACHINE:

- 2200 kg

Generating set pictured may include optional accessories.



## DIMENSIONS DRAW

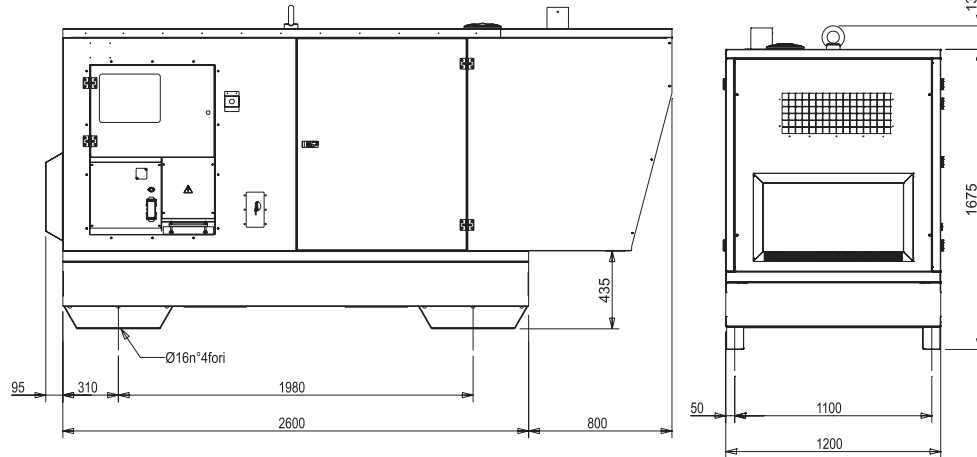

## OPTIONS ON REQUEST

- Automatic transfer switch unit (ATS) PAC 275 M (400A)
- Remote control TCM35
- Earthing kit



## VERSIONS ON REQUEST

- Version with manual control panel 6 output sockets EC and SCHUKO (see Control board with output sockets section)
- Manual digital control panel (without sockets)
- Parallel switch board



## FACTORY INSTALLATION OPTIONS

- Electronic leakage relay
- Isometer
- Volt adjustable from control panel
- Radio control
- Fuel tank 120 lt.
- Fuel tank 350 lt.
- Fuel tank 840 lt.
- Spark arrestor
- Automatic fuel transfer system
- Engine water heater WH
- 3-way valve fuel system with quick connection for external fuel tank supply
- Main battery switch
- Plug-in module with double RS232 and RS485 port
- GSM modem with antenna
- GPS / 4G modem with antenna
- Internet / Ethernet plug-in module with Web Server
- Input / Output extension module (No. 16 tot.)

## GENERAL INFORMATION

### COMPLIANCE GENERATING SETS WITH EC DIRECTIVES AND STANDARDS

- 2006/42 / EC (Machines Directive)
- 2014/35 / EU (Low Voltage Directive)
- 2014/30 / EU (EMC Directive)
- 2000/14 / EC (Directive Acoustic Emission for machines for use outdoors)
- ISO 8528 (Reciprocating internal combustion engine driven alternating current generating sets)



ISO 9001:2008 - Cert. 0192

### WARRANTY

All devices are covered by the manufacturer's warranty.

The company reserves the right to change this specification without notice. For further information please contact the sales department.

© MOSA - Viale Europa, 59 - 20090 Cusago (Milano) - Italy - phone +39-0290352.1 - fax + 39-0290390466 E-mail: info@mosa.it Web site: www.mosa.it

