

# GENERATING SET GE 35 YSX SINGLE-PHASE

The images are for reference



## FEATURES

- Stage 3A compliant engine
- Automatic voltage regulation AVR
- The rounded edges of the canopy designed for rainwater drainage away
- Bunded base suitable to contain any liquids leakage from engine avoiding environmental pollution
- External caps for oil and water drain
- Large doors for better and easy maintenance (air, oil, fuel filters replacement)
- Central lifting eye
- Forklift pockets
- Ready for connection to automatic transfer unit EAS (AMF + ATS)
- Meets EC directives for noise and safety



water cooled



diesel



single-phase power



electric



super silenced

## POWER RATINGS

* Stand-By single-phase power	31 kVA (kW) / 230V - 115V / 134.8 A - 269.6A
* PRP single-phase power	28 kVA (kW) / 230V - 115V / 121.7 A - 243.5A
* COP power	/
Frequency	50 Hz
Cos φ	0.8

\* Output powers according to ISO 8528-1

## DEFINITION

Valid declared powers up to the followings environmental conditions: temperature 25°C, altitude 100 meters above sea level

**LTP power: stand-by power:** Maximum available power for use with variable loads for a yearly number of hours limited at 500 h. No overload is admitted.

**PRP power:** continue power with variable loads. Maximum power for use with variable loads for a yearly illimited nubers of hours.

**COP power:** continuous power with constant load. Maximum power for use with constant loads for a yearly unlimited numbers of hours.

## ENGINE 1500 RPM

### 4 STROKE, DIRECT INJECTION, NATURAL ASPIRATED

Model	YANMAR 4TNV98
* Stand-By net power	34.1 kW (46.4 hp)
* PRP net power	30.7 kW (41.7 hp)
* COP net power	/
Cylinders / Displacement	4/ 3.3. lit.
Bore / Stroke	98 / 110 (mm)
Compression ratio	18.5 : 1
BMEP (Brake Mean Effective Pressure : LTP - PRP)	/
Speed governor type	Mechanical
<b>FUEL CONSUMPTION</b>	
110 % (Stand-by power)	9 lit./h
100 % to PRP	8.1 lit./h
75 % to PRP	6.1 lit./h
50 % to PRP	4.2 lit./h
<b>COOLING SYSTEM</b>	
Total system cap. - only engine	9 lit. - 4.2 lit.
Fan air flow	70 m <sup>3</sup> /min
<b>LUBRICATION SYSTEM</b>	
Total oil system capacity	/
Oil capacity in sump	5.5 lit. (min) - 10.5 lit. (max)
Oil consumption at full load	/

\* Output powers according to ISO 3046-1

## EXHAUST SYSTEM

Maximum exhaust gas flow	/
Max. exhaust gas temp.	630 °C
Maximum back pressure	9.8 kPa (0.1 bar)
External diameter exhaust pipe	/
<b>ELECTRICAL SYSTEM</b>	
Starter motor power	2.3 kW
Battery charging alternator cap.	40 A
Cold start	- 15 °C
With cold start aid	/
<b>AIR FILTER</b>	
Combustion air flow	2.2 m <sup>3</sup> /min
<b>HEAT REJECTED AT FULL LOAD</b>	
To exhaust system	/
To water and oil	/
Radiated to room	/
To charge cooler	/



## ALTERNATOR

SYNCHRONOUS, THREE-PHASE, SELF-EXCITED, SELF-REGULATED, BRUSHLESS	
Continuous power	28 kVA
Stand-by power	31 kVA
Three phase voltage	220-240V / 110-120V
Frequency	50 Hz
Cos φ	0.8
Model A.V.R.	HVR-30
Voltage regulation acc.	± 1.0 %
Sustained short circuit current	3 In
Transient dip (100% load)	10 %
Recovery time	≤ 3 sec.
Efficiency at 100% load	89.3 % (230V - Cos φ 0.8)
Insulation	Class H
Connection - Terminals	ZIG ZAG - N°12
Electromagnetic compatibility (R.F.I. suppr.)	EN 55011
Waveform distortion - THD	< 3 %
Telephone interference - THF	< 2 %

REACTANCES (20 kVA - 400V)	
Direct axis synchronous - Xd	240 %
Direct axis transient - X'd	18 %
Subdirect axis transient - X''d	7 %
Quadrature axis synchronous - Xq	133 %
Quadr. axis subtransient - X''q	/
Negative sequence - X2	/
Zero sequence - X0	/
TIME CONSTANTS	
Transient - T'd	0.01 sec
Subtransient - T''d	0.006 sec
Open circuit - T'do	0.147 sec
Armature - Ta	/
Short-circuit ratio Kcc	0.58
Cooling air flow	0.13 m³/sec.
Coupling   Bearing	Diretto SAE 3 -11.5 ½ - N°1

## GENERAL SPECIFICATIONS

Fuel tank capacity	100 lt.
Running time (75% to PRP)	16.5 h
Starter battery	12 Vdc -80Ah
IP protection degree	IP 44

* Measured acoustic power LwA (pressure LpA)	91 dB(A) (66 dB(A) @ 7m)
* Guaranteed acoustic power LwA (pressure LpA)	91 dB(A) (66 dB(A) @ 7m)
Performance class (ISO 8528)	G2

\* Acoustic power according to European Directive 2000/14/CE

## CONTROL PANEL

- Controller EP6
- Fuel level gauge
- Siren
- Emergency stop button
- Local-Remote Start switch
- EAS plug
- TCM 35 remote control plug
- Four pole circuit breaker
- Terminal output with bus bar
- Circuit breakers
- Earth terminal (PE)

EP6 CONTROLLER CHARACTERISTICS	
Operating mode	OFF - MAN. - AUTO
Display	4-digits display
LEDs	Engine is running AUTO mode
Buttons/controls	Starter key AUTO button N° 5 buttons for controller programming
Measures	Generator voltage Generator current Frequency Engine speed Battery voltage Charger battery voltage Hourmeter
Alarms	Low oil pressure High temperature Belt break Low level fuel Emergency stop button Starting failure Over-under generator voltage Over-under frequency Over-under speed High-low battery voltage Overload generator Internal memory failure
Functions	Remote starting (only to AUTO) Cold start aid Automatic periodic test (only to AUTO) Generator contactor control

# WEIGHT - DIMENSIONS AND ACCESSORIES

GE 35 YSX  
SINGLE-PHASE



### DRY WEIGHT MACHINE:

- 960 Kg (tank version 100 lt)
- 1150 Kg (tank version 350 lt)

Generating set pictured may include optional accessories.



### DIMENSIONS DRAW

- 2050 x 900 x 1730 mm (tank version 350 lt)
- For version with **100 lt tank**, see the illustrations as shown below.

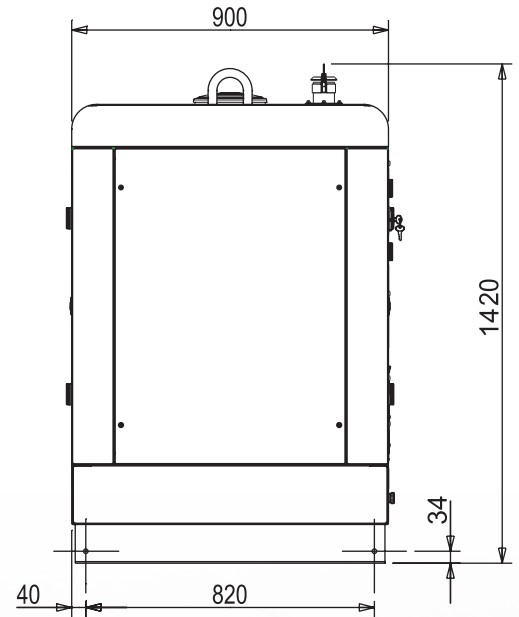
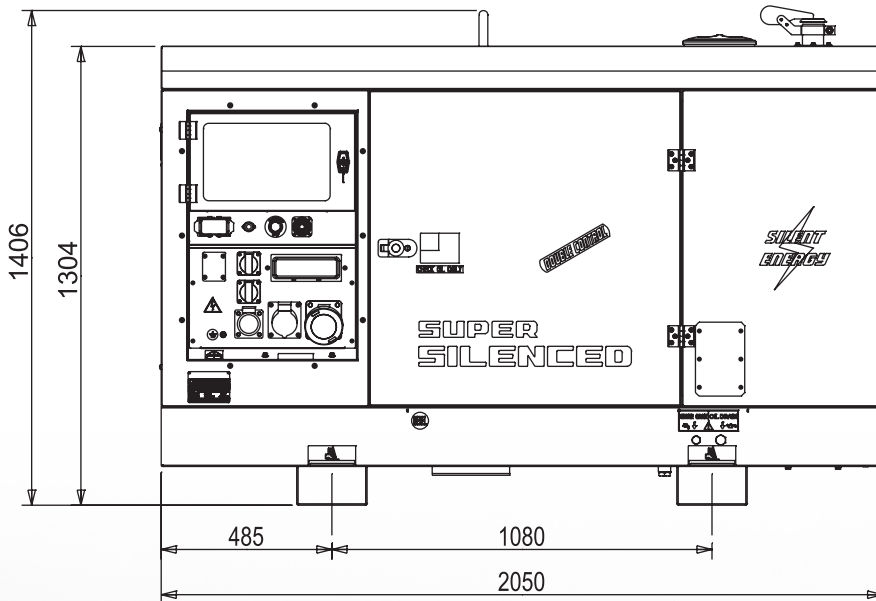

### OPTIONS ON REQUEST

- Automatic transfer unit EAS 42 - 809 (60 A)
- Remote control TCM35
- Site tow CTL20
- Road trailer CTV1/0
- Road trailer CTV1/S
- Earthing kit
- Galvanized skid base frame



### VERSIONS ON REQUEST

• /



### FACTORY INSTALLATION OPTIONS

- Engine heater
- Gauges - water temperature and oil pressure
- Spark arrestor
- 3-way valve fuel system with quick connection for external fuel tank supply
- 350 litre internal tank
- Main battery switch
- Electronic leakage relay
- Isometer
- Radio control

## GENERAL INFORMATION

### COMPLIANCE GENERATING SETS WITH EC DIRECTIVES AND STANDARDS

- 2006/42 / EC (Machines Directive)
- 2014/35 / EU (Low Voltage Directive)
- 2014/30 / EU (EMC Directive)
- 2000/14 / EC (Directive Acoustic Emission for machines for use outdoors)
- ISO 8528 (Reciprocating internal combustion engine driven alternating current generating sets)



ISO 9001:2008 - Cert. 0192

### WARRANTY

All devices are covered by the manufacturer's warranty.

The company reserves the right to change this specification without notice. For further information please contact the sales department.

© MOSA - Viale Europa, 59 - 20090 Cusago (Milano) - Italy - phone +39-0290352.1 - fax +39-0290390466 E-mail: info@mosa.it Web site: www.mosa.it

